

DBP Digital Beltpack

DBP 4M | DBP 4F | DBP 5F

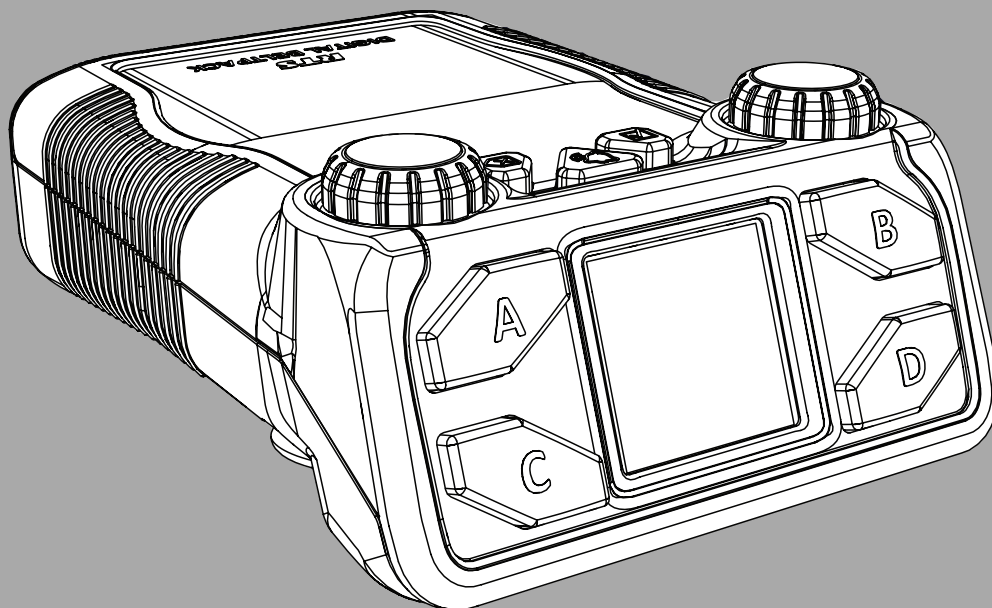

Table of contents

1	Safety	6
1.1	Copyright and Disclaimer	6
1.2	Notices	6
1.3	Important safety instructions	7
1.4	Revision history	7
2	Introduction	9
2.1	Features	9
3	Reference view	10
3.1	Belt clip removal and replacement	11
4	Cabling	12
4.1	To OMS	12
4.2	To OMI	13
4.3	To ODIN	13
4.4	PoE	14
5	Install the Bluetooth dongle	16
6	Create an Intercom connection	17
6.1	Connect to OMS using Connect Devices	17
6.2	Configure intercom OMNEO ports to make connection offers	17
6.2.1	Configure OMS to make a connection offer	17
6.2.2	Configure ODIN to make a connection offer	18
6.3	Accept a connection offer on DBP	19
6.4	Create connections using IPedit	19
6.4.1	Add DBP to IPedit	19
6.4.2	Configure an OMNEO channel for DBP using IPedit	20
6.4.3	Configure the DBP to accept an OMNEO offer using IPedit	22
6.5	Create connections using AZedit	23
6.5.1	Configure OMS/ODIN to make a connection offer	23
6.5.2	Configure an OMI card to make a connection offer	24
7	Modes of operation	26
7.1	PL Mode	26
7.2	Keypanel Mode	26
8	Basic Operation	27
8.1	Main screen icons	27
8.2	Navigation basics	28
8.3	Hot keys	29
8.4	UI controls	32
8.5	Volume adjustment	33
8.5.1	Master volume adjustment	33
8.5.2	Individual key volume adjustment	34
8.5.3	Adjust volume for OMNEO 2, Bluetooth, and 3.5mm input volumes	34
8.5.4	Mute a PL key assignment	34
8.5.5	Adjust Matrix In level in AZedit	35
8.6	Call Signaling	36
8.7	Talk and Listen	36
8.8	Call waiting window	37
8.9	Bluetooth	39
8.9.1	Answer a phone call via Bluetooth	40
8.9.2	Phone call management window	41

8.9.3	Patch a phone call to the Intercom	41
8.10	Upgrade firmware	43
8.11	Download screen saver images or splash screen images	46
8.12	Priority Call Volume Control	47
9	Menu Structure	49
9.1	Setup Network	49
9.1.1	Device Name	50
9.1.2	DHCP	51
9.1.3	IP Address	51
9.1.4	Netmask	52
9.1.5	Gateway	53
9.1.6	DNS Server	54
9.1.7	Domain	55
9.1.8	MAC Address	56
9.2	Setup Offers	56
9.2.1	DBP Offers	56
9.2.2	Aux Offers	57
9.3	Setup Key Assignments	57
9.3.1	Change Setup Page	59
9.4	Setup Service	60
9.4.1	Tone	60
9.4.2	Test Mode	61
9.4.3	User Reset	62
9.4.4	Factory Reset	63
9.5	Setup Authentication	64
9.5.1	Require PIN	64
9.5.2	Set PIN	65
9.6	Setup Key Modes	66
9.7	Audio Headset	67
9.7.1	Sidetone	67
9.7.2	Echo Cancellor	68
9.8	Audio Microphone	69
9.8.1	Mic Select	69
9.8.2	Mic Gain	69
9.8.3	Hot Mic	70
9.8.4	Noise Gate	71
9.8.5	XLR Mic Type	72
9.8.6	Allow Mic Kill	72
9.8.7	Send Mic Kill	73
9.9	Audio 3.5mm Aux	74
9.9.1	Aux Mode	74
9.9.2	Input Gain	75
9.9.3	Output Gain	75
9.9.4	Aux Stereo Mix	76
9.10	Audio BT Aux Levels	78
9.10.1	Input Gain	78
9.10.2	Output Gain	78
9.11	Audio OMNEO CH 2 Levels	79
9.11.1	Input Gain	79

9.11.2	Output Gain	80
9.12	Audio Mixer	80
9.12.1	Headset L+R	80
9.12.2	Headset Left	81
9.12.3	Headset Right	82
9.12.4	To Intercom	82
9.12.5	3.5mm Aux Out	83
9.12.6	OMNEO Ch2 Out	83
9.12.7	Bluetooth Out	84
9.13	Call Alerts	85
9.13.1	Call Beep	85
9.13.2	Call Vibration	85
9.14	Information	86
9.15	Bluetooth	87
9.15.1	Ready to Pair	87
9.15.2	Paired Headsets	88
9.15.3	Paired Aux Devs	90
9.16	Display	91
9.16.1	Display Mode	91
9.16.2	Brightness	92
9.16.3	Screen Saver	93
9.16.4	Screen Flip	94
10	Icons	95
11	Technical data	98

1 Safety

1.1 Copyright and Disclaimer





All rights reserved. The product information and design disclosed herein were originated by and are the property of Bosch Security Systems, LLC. Bosch reserves all patent, proprietary design, manufacturing, reproduction, use and sales rights thereto, and to any article disclosed therein, except to the extent rights are expressly granted to others.

No part of this document may be reproduced or transmitted in any form by any means, electronic, mechanical, photocopying, recording, or otherwise, without the prior written permission of the publisher. For information on getting permission for reprints and excerpts, contact Bosch Security Systems, LLC.

All other trademarks are property of their respective owners.

The content and illustrations are subject to change without prior notice.

1.2 Notices

	CE Compliant and UL Certified	
		
	<div style="border: 1px solid black; padding: 5px; text-align: center;"> <p>CAUTION</p> <p>RISK OF ELECTRIC SHOCK DO NOT OPEN</p> </div>	
<p>The lightning flash and arrowhead within the triangle is a warning sign alerting you of dangerous voltage inside the product.</p>	<p>Caution: To reduce the risk of electric shock, do not remove cover. No user-serviceable parts inside. Refer servicing to qualified service personnel</p>	<p>The exclamation point within the triangle is a warning sign alerting you of important instructions accompanying the product.</p>
<p>See marking on bottom/back of product.</p>		



Warning!

Apparatus shall not be exposed to dripping or splashing and no objects filled with liquids, such as vases, shall be placed on the apparatus.



Warning!

This is a CLASS A product. In a domestic environment, this product may cause radio interference, in which case the user may be required to take adequate measures.

**Warning!**

To reduce the risk of fire or electric shock, do not expose this apparatus to rain or moisture.

1.3 Important safety instructions

1. Read these instructions.
2. Keep these instructions.
3. Heed all warnings.
4. Follow all instructions.
5. Do not use this apparatus near water.
6. Clean only with a dry cloth.
7. Do not install near any heat sources such as radiators, heat registers, stoves, or other apparatus (including amplifiers) that produce heat.
8. Only use attachments/accessories specified by the manufacturer.
9. Use only with the cart, stand, tripod, bracket, or table specified by the manufacturer, or with the apparatus. When a cart is used, use caution when moving the cart/apparatus combination to avoid injury from tip-over.
10. Unplug the apparatus during lightning storms or when unused for long periods of time.
11. Refer all servicing to qualified service personnel. Servicing is required when the apparatus has been damaged in any way, such as power-supply cord or plug is damaged, liquid has been spilled or objects have fallen into the apparatus, the apparatus has been exposed to rain or moisture, does not operate normally, or has been dropped.

1.4 Revision history

Revision	Revision date	Change description	
01	06/2021	Initial release	
02	08/2023	Sec. 8.5	Added Adjust Matrix In level in AZedit section in Volume Adjustment chapter
		Sec. 8.6	Updated call signal chapter to include call signal in KP mode note
		Sec. 8.12	Added priority call chapter
		Sec. 9.3.1	Added change setup pages chapter
		Sec. 9.8.4	Added noise gate limiter note to noise gate chapter
	Sec. 9.9.4	Added aux stereo mix feature	
03	03/2024	Sec 10.5	Aux/Bluetooth/OMNEO CH2 volumes can now be accessed from the home screen (in addition to via the menus). Press and hold the CLR/BACK button while rotating a shaft encoder to

Revision	Revision date	Change description	
			enter aux volume mode. Once entered, each press of a shaft encoder button cycles the next aux volume type
		Sec. 11.5.2, 11.5.3, 11.5.4, 11.9.7	Action button widgets now automatically launch when the widget is activated (instead of requiring a second press of the MENU/SEL key)
		Sec. 10.3	Quick access to the last menu item accessed by pressing and holding CLR/BACK and then pressing and releasing MENU/SEL.

2 Introduction

The **DBP** (Digital Belt Pack) is one of RTS' initial offerings in the wired digital party line solution space. The DBP provides two modes in which the DBP can operate for up to four configurable audio conferences. There are two modes DBP can operate, **KP** (Keypanel) mode and **PL** (Party Line) mode. When connected to an intercom in KP mode, any key assignment that is made to a keypanel can be made on the DBP. When connected to an OMS, the assignment types are limited to PL, **RY** (relays), and **UR** (UPL resources).

When connected to the **OMS** (OMNEO Main Station), the DBP operates as a digital party line device. The DBP also connects to any of the RTS matrix products directly via OMNEO. This includes OMI cards in ADAM (or ADAM -M) frames or OMNEO ports on ODIN frames. When connected to an RTS OMNEO matrix, the DBP acts as a wired, 4-button keypanel. The DBP automatically determines the correct mode of operation (digital party line connection to OMS or keypanel connection to the matrix) at power on.

The DBP recovers power over an 802.3af or 802.3at compliant Ethernet interface. The PoE (power over Ethernet) In port connects to a PoE compliant power sourcing equipment. The PoE Out port is available for daisy chain connections to other DBPs.

The DBP comes in a rugged, over-molded enclosure that is IP-53 compliant. It has a full-color TFT display and an icon-based menu interface, which allows for local configuration of essential customer preferences.

2.1 Features

- Incorporates both XLR and 3.5 mm TRRS connectors for headsets, and the XLR headsets are available in 3 different headset XLR options: 4-pin female, 4-pin male, and 5-pin female. The 5-pin female headset supports stereo audio.
- PoE powered via an 802.3af or 802.3at managed switch or PoE injector. Contains a PoE In and PoE Out port, which allows up to six DBPs to be daisy-chain connected to the same PoE (+) switch port.
- DBP connects to an OMNEO main station (Digital Party Line) or an OMNEO capable matrix (OMI card or ODIN). DBP can support up to four active Party Lines. 40 DBPs can be connected to OMS (based on model), 64 DBPs can be connected to one OMI card (based on model), 128 DBPs can be connected to one ODIN, based on model).
- Supports Bluetooth audio connectivity using either an IO Gear GBU522 dongle or an LM Technologies LM506 dongle.
- Incoming CALL notifications via audible alerts or haptic vibration.

3 Reference view

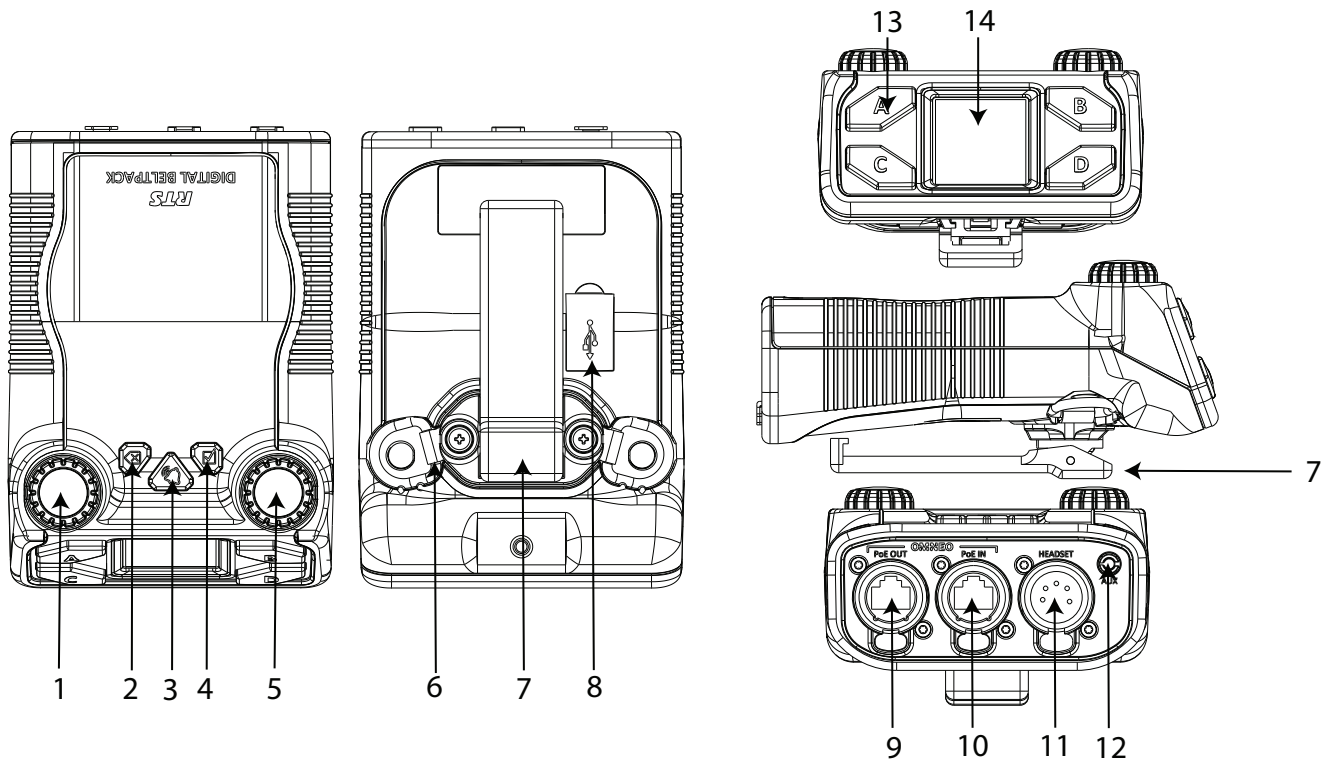

1	Master Volume Control knob / Key A and C Volume knob
2	CLR/BACK button
3	CALL button
4	SEL/MENU button
5	Master Volume Control knob / Key B and D Volume knob
6	Lanyard loop
7	Belt Clip
8	USB Bluetooth dongle connector
9	PoE Out connector
10	PoE In connector
11	XLR Headset connector
12	3.5mm AUX connector
13	Talk keys (A, B, C, and D)
14	Display screen

3.1 Belt clip removal and replacement

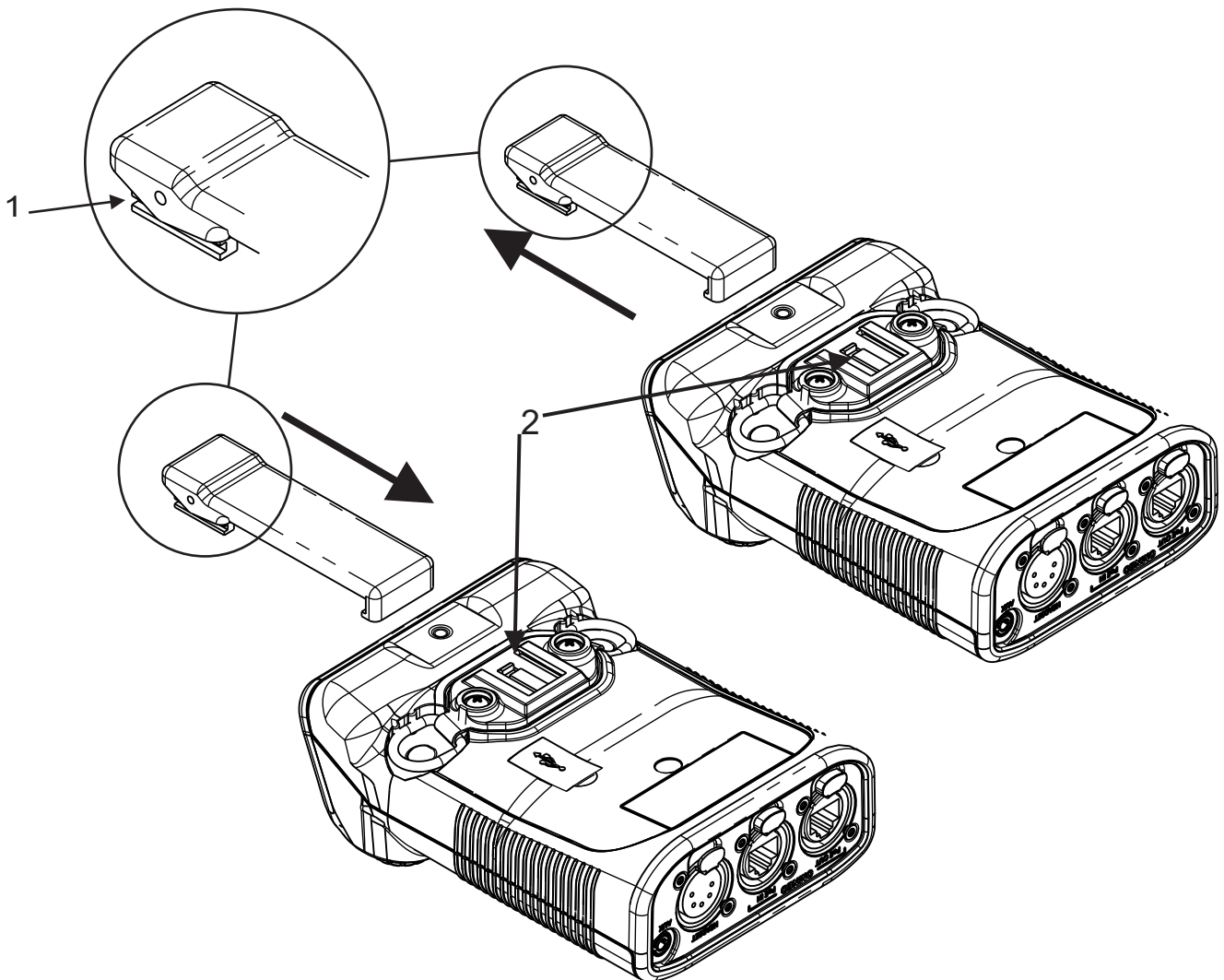

To **remove the belt clip**, do the following:

1. Lift the tension clip (1) up.
2. With the tension clip up, slide the **belt clip out of the belt clip track (2)**.

To **replace the belt clip**, do the following:

- ▶ **Align and slide the belt clip into the belt clip track (2)**.
A click is felt/heard when the belt clip is securely in place.

4 Cabling

4.1 To OMS



Notice!

PoE is not necessary as long as it is on a network that can reach the DBP.

To **cable the DBP to an OMS main station**, do the following:

1. Using a CAT-5e cable, attach **one end to the PoE IN connector** on the DBP.
2. Connect the **other end of the cable** to an approved PoE switch.

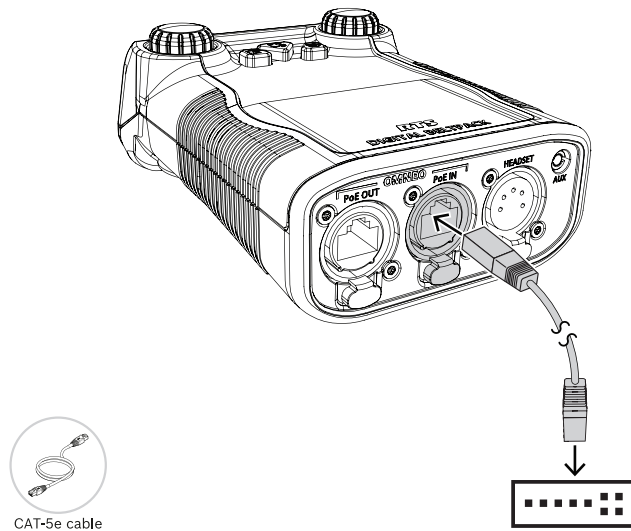

CAT-5e cable

3. Using a second CAT-5e cable, connect **one end to the approved PoE switch**.
4. Connect the **other end to the OMNEO connector** on the OMS device.

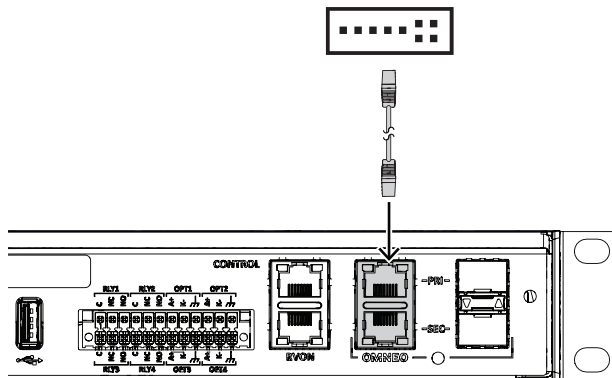

PoE Switch



CAT-5e cable



Notice!

If using IPedit to configure the connection between the DBP and the OMS, a third cable is needed to connect the OMNEO port to the PoE switch.

For information on connecting the DBP to the OMS, see *Configure OMS to make a connection offer*, page 17.

4.2 To OMI

To **connect a DBP to an OMI card**, do the following:

1. Using a CAT-5e cable, attach **one end to the PoE IN connector** on the DBP.
2. Connect the **other end of the cable** to an approved PoE switch.

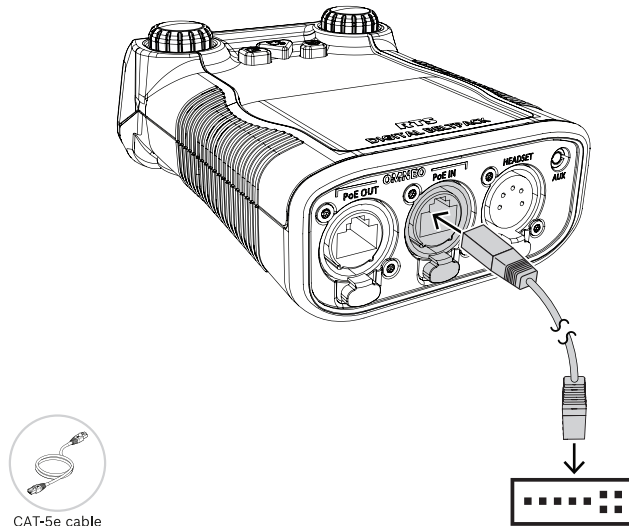

3. Using a second CAT-5e cable, connect **one end to the approved PoE switch**.
4. Connect the other end to an Ethernet connector on the OMI card.

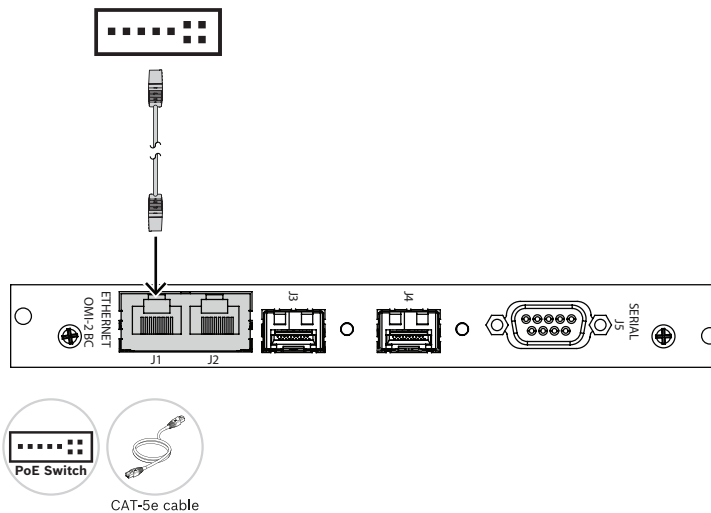

For information on connecting the DBP to the OMI card, see *Configure an OMI card to make a connection offer*, page 24.

4.3 To ODIN

To **connect the DBP to an ODIN matrix**, do the following:

1. Using a CAT-5e cable, attach **one end to the PoE IN connector** on the DBP.
2. Connect the **other end of the cable** to an approved PoE switch.

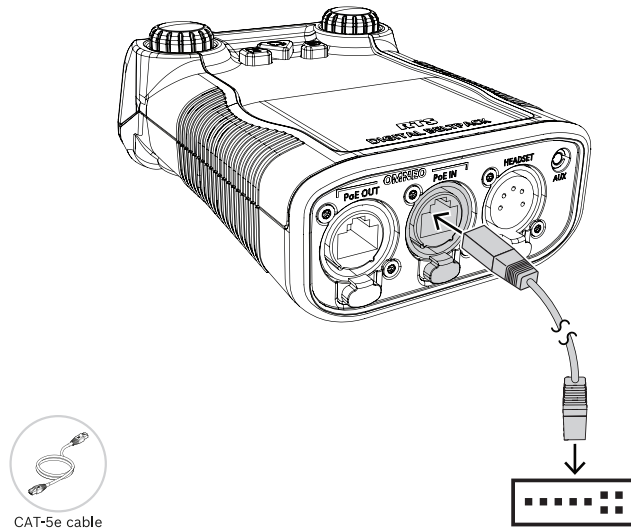

CAT-5e cable

3. Using a second CAT-5e cable, connect **one end to the approved PoE switch**.
4. Connect **the other end to the OMNEO port** on ODIN.

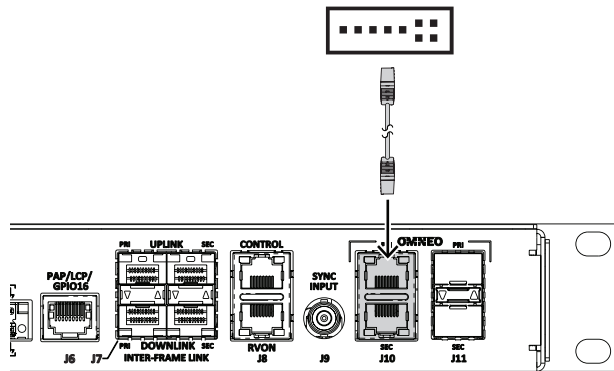

PoE Switch



CAT-5e cable



Notice!

If using IPedit to configure the connection between the DBP and ODIN, use a third cable to connect the OMNEO port to the PoE switch.

For information on how to connect the DBP to an ODIN, refer to *Configure ODIN to make a connection offer*, page 18.

4.4

PoE

The Digital Belt Pack includes a PoE In and PoE Out connector that allows multiple DBPs to be daisy chained from the same switch port. RTS recommends use of an 802.3at compliant PoE switch for daisy chaining. RTS guidance on the number of DBPs that can be daisy chained from an 802.3at port are as follows:

- Using CAT-5e cable or better, up to six DBPs can be daisy chained where each daisy chain span has a length of 100 foot (30 m) or less (total of 600 feet / 180 meters of cable).

- Using CAT-5e cable or better, up to three DBPs can be daisy chained where each daisy chain span has a length of 328 foot (100 m) or less (total of 984 feet / 300 meters of cable).



Notice!

It is possible to use PoE injectors on the end of a daisy chain to extend the number of DBPs and cable lengths supported

Using more than 6 DBPs on the same 802.3at switch port may result in unreliable beltpack operation.

To **daisy chain belt backs together**, do the following:

1. Connect one end of a CAT-5e cable from the **PoE Out connector on one DBP belt pack**.
2. Connect the other end of the CAT-5e cable to the **PoE In connector on a second DBP belt pack**.
3. Connect one end of a second CAT-5e cable to the **PoE Out connector on the second DBP belt pack**.
4. Connect the other end of the second CAT-5e cable to the **PoE In connector on a third DBP belt pack**.
5. Repeat these **steps** to add additional belt packs to the daisy chain.

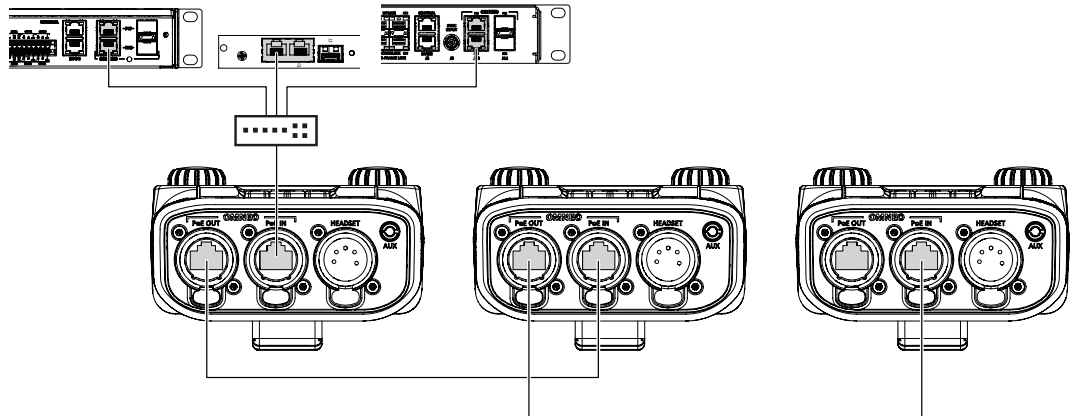

Figure 4.1: Daisy Chain Example

5 Install the Bluetooth dongle

It is best to install the dongle when there is no power to the device. If you install the dongle while the DBP is on, the belt pack recognizes the dongle and reboots to initialize the hardware properly. If you remove the dongle while the DBP has power, it does not reboot.



Notice!

Optimal Bluetooth audio quality is achieved when the DBP is paired with a headset that incorporates a boom microphone construction versus Bluetooth headsets with embedded microphones (i.e., ear buds).

To **install the Bluetooth dongle**, do the following:

1. Open the **USB connector door** (1).
Take care not to over-extend the door.
2. Insert the **dongle** (2) in the connector.

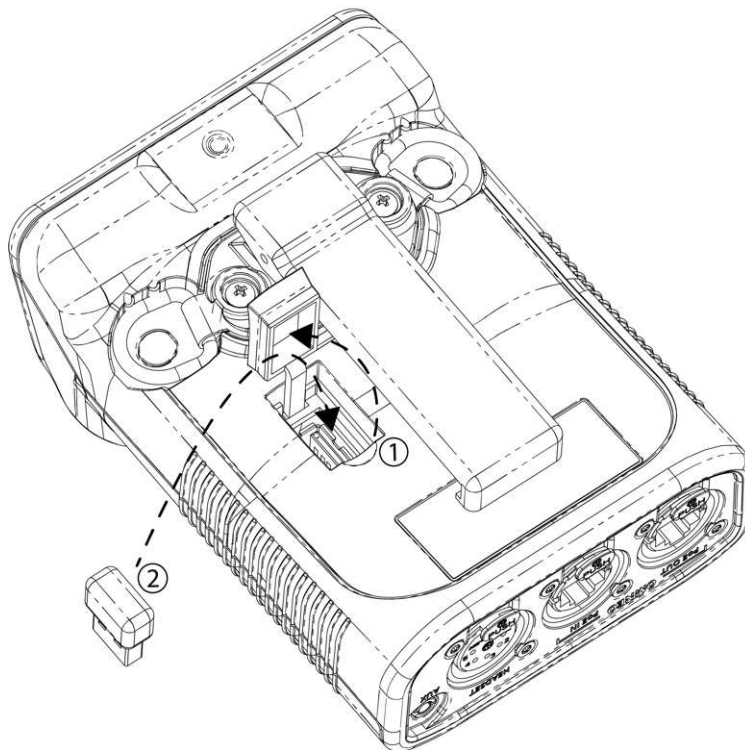

Figure 5.1: DBP USB dongle installation

3. Close the **USB connector door** (1).
4. Push the **door surface** to ensure the door is within the DBP enclosure.

6 Create an Intercom connection

6.1 Connect to OMS using Connect Devices

To **connect OMNEO devices via the OMS front panel UI**, do the following:

1. Navigate to **Connect Devices** menu item (**Configuration | Ports | Connect Devices**).
2. Click the **ENC2 encoder knob**.
OMS scans for available OMNEO devices, and then shows devices that support Easy Connect (KP-Series, DBP, OKI, etc.). Discoverable devices need to be powered on, connected to the network, and be on the same subnet.

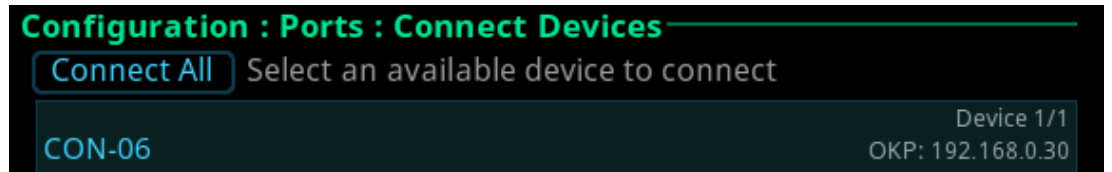

3. Navigate to the **Connect All** button.
OR
Navigate to the **OMNEO device**.

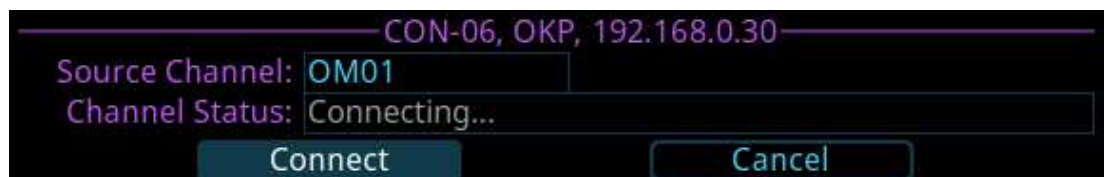

4. Select the **Connect** button.

6.2 Configure intercom OMNEO ports to make connection offers

6.2.1 Configure OMS to make a connection offer



Notice!

For more information, see the OMS manual found at www.rtsintercoms.com.

To **connect a DBP to OMS**, do the following:

1. Navigate to the **OMNEO icon** (**Configuration | Ports | OMNEO**).
2. Click the **ENC2 encoder knob**.
The OMNEO Channels screen displays.

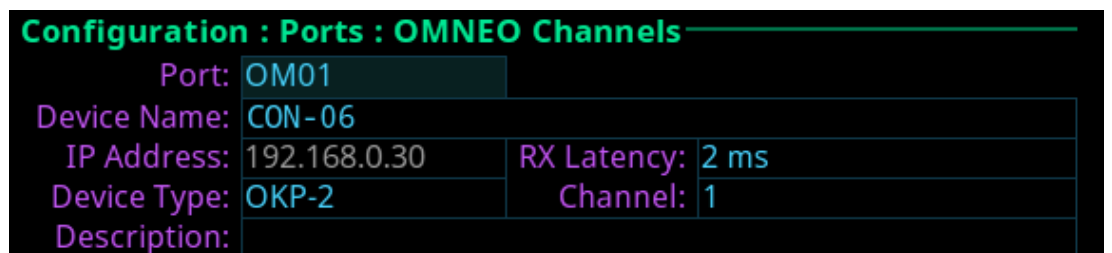

3. Select the **port to configure**.

**Notice!**

If you are connecting a DBP or Keypanel in order to power it up on this port, choose Channel 1. Any other port is an Aux port and the DBP has only two channels.

1. Enter the **device name** of the partner device to connect to this port.
2. Select the **type** of partner device.
3. Select the **channel number** on the partner device to connect to.
4. (Optional) Change the **Rx Latency** for the connection.
The default is recommended.
5. When finished, press **ENC1** to exit.
6. Choose **Save** to save the changes.

6.2.2**Configure ODIN to make a connection offer****Notice!**

For more information, see the ODIN manual found at www.rtsintercoms.com.

To **connect a DBP to an ODIN**, do the following:

1. Navigate to the **OMNEO icon**.
2. Click the **right encoder knob**.

The OMNEO Channels screen displays.

Configuration: Ports: OMNEO Channels			
Frame:	2	Port:	CAM7 (N007)
Device Name:	CAP6-0b18a4.local.		
IP Address:	169.254.197.133	RX Latency:	1 ms
Device Type:	OKP-2	Channel:	1
Description:			

**Notice!**

If the intercom system contains only one ODIN frame, the Frame field is not displayed. If the intercom system contains multiple ODIN frames, the Frame field activates and allows ports in other frames to be selected and configured. While the Frame field is highlighted, press the right encoder knob to activate the field. Once activated, turn the right encoder knob to select another frame in the system.

3. Navigate to the **Port field**.
4. Click the **right encoder knob**.
The Port field becomes active.
5. Scroll to the **desired port**.
6. Navigate to the **Device Name field**.
7. Enter the **device name of the partner device** to connect to this port.
8. Navigate to the **Device Type field**.
9. Scroll to the **OMNEO device type** of the partner device.
10. Navigate to the **channel field**.
11. Scroll to the **desired channel** on the partner device.
12. (Optional) Enter a **description** for this connection.

13. (Optional) Select the **latency** to use for this connection. (1 ms is recommended for best quality).
14. Click the **left encoder knob** to exit the screen.
A Changes Made confirmation message displays.

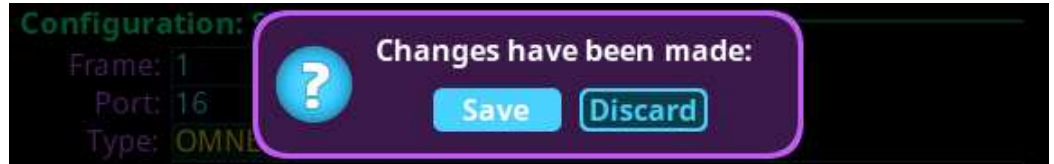

15. Navigate to the **desired action**.
16. Click the right encoder knob to **confirm**.



Notice!

Alternately, click the left shaft encoder or press the CLR button to cancel this prompt and go back to editing the underlying screen.

17. Click the right encoder knob to **confirm the selection**.

6.3 Accept a connection offer on DBP

To **accept a DBP Offer**, do the following:

1. Navigate to the **DBP Offers menu item** (Setup | Offers | DBP Offers).
2. Press the **SEL/MENU button**.
The field highlights.



3. Rotate either **shaft encoder** to scroll through the available offers.
4. Press the **SEL/MENU button** to confirm the change, or press the **CLR/BACK button** to abort changes.

6.4 Create connections using IPedit

6.4.1 Add DBP to IPedit

To **add a DBP to IPedit**, do the following:

1. Open **IPedit**.
2. Select **Add from the Device menu**.
The Add Devices screen displays.

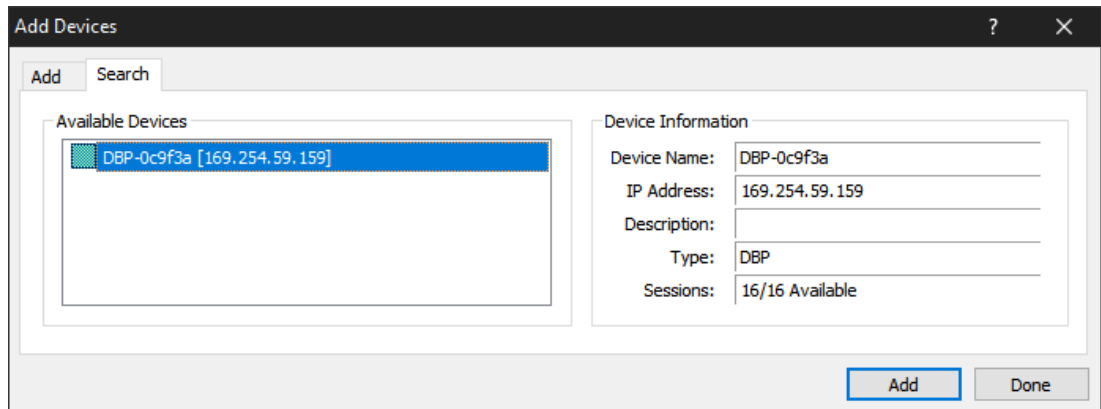

3. Select **one or more available devices**.
The Add button becomes active.
4. Click the **Add button**.
The device catalog displays the selected devices.

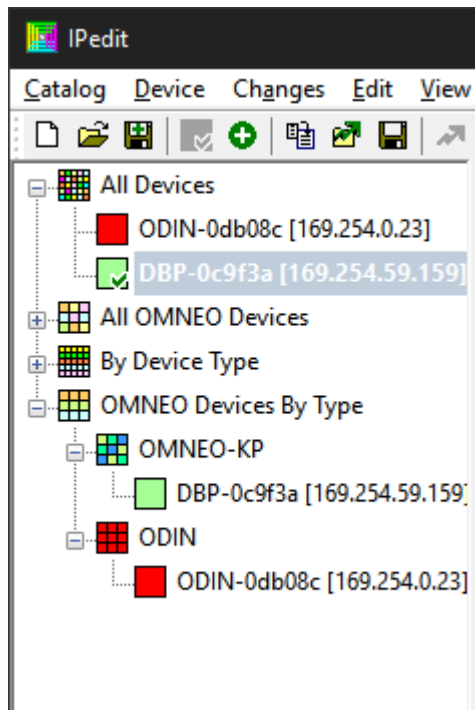

5. Click the **Done button**.
The screen closes.

6.4.2

Configure an OMNEO channel for DBP using IPedit

To **configure an OMNEO channel for DBP using IPedit**, do the following:



Notice!

The Destination Type does not need to be selected if using the Browse window to select the device. It fills the type and IP Address automatically.

Using the Channel Configuration Pane

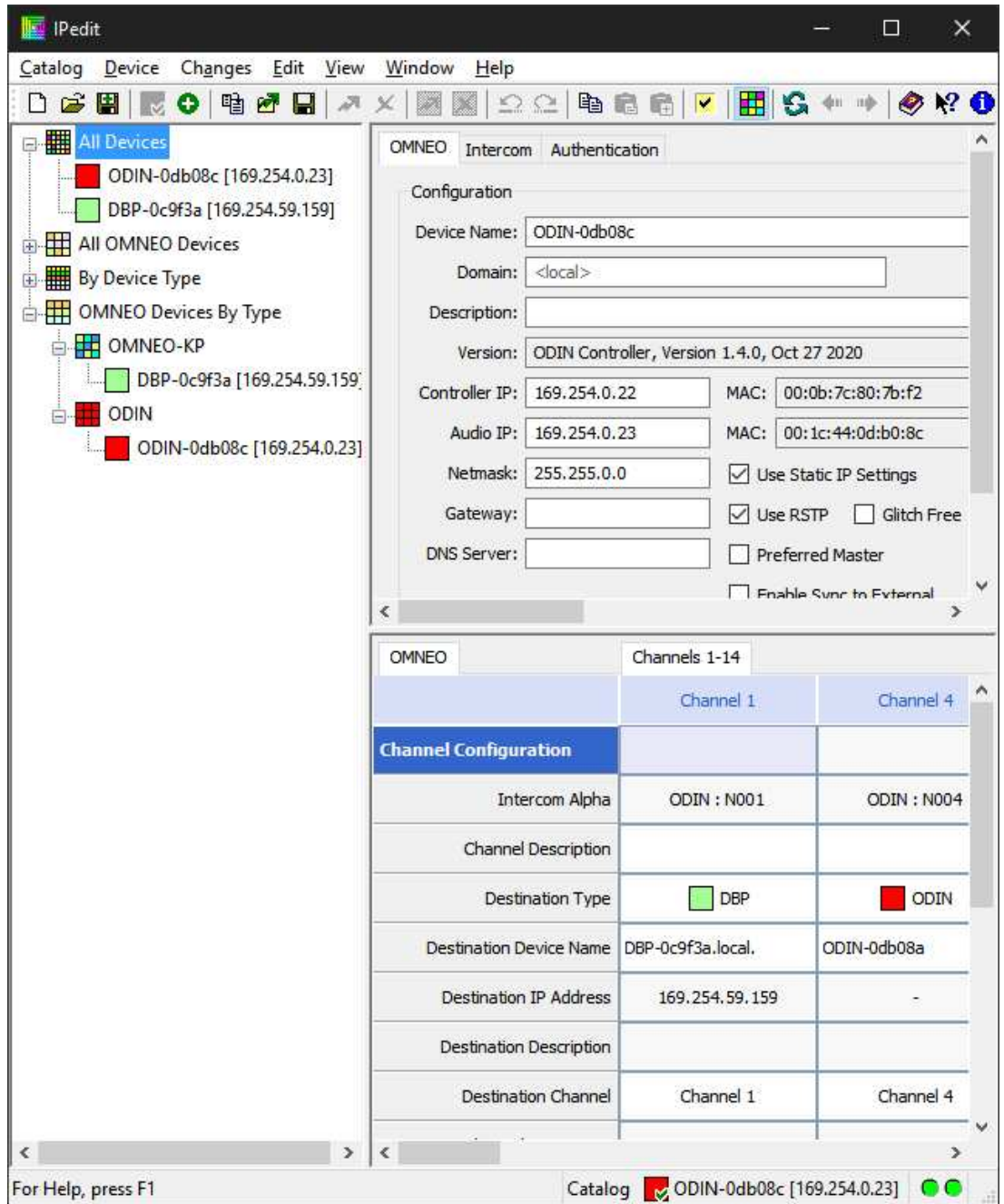

1. In the Destination Device Name field, click the ... **button**.
The Discovered Devices screen displays.
2. Expand the **tree** to view the destination devices available.
3. Select the **desired device** for the destination.
4. Click **OK**.
The screen closes.
5. Select the **channel** to which the device connects.
6. (Optional) Enter the **channel description**.

6.4.3

Configure the DBP to accept an OMNEO offer using IPedit

As an alternative to accepting offers through the DBP user interface, use IPedit to configure the DBP to accept connection offers from ODIN. For information on using the DBP user interface to accept connection offers, refer to *Accept a connection offer on DBP*, page 19.

To **configure the DBP to accept an OMNEO offer using IPedit**, do the following:



Notice!

The Destination Type does not need to be selected if using the Browse window to select the device. It fills the type and IP Address automatically.

OMNEO	Channels 1-2	
	Channel 1	Channel 2
Channel Configuration		
Intercom Alpha	ODIN : N001	
Channel Description		
Destination Type	ODIN	OMS
Destination Device Name	ODIN-0db08c.local.	ODIN-0db08c.local.
Destination IP Address	169.254.0.23	169.254.0.23
Destination Description		
Destination Channel	Channel 1	Channel 1
Destination Channel Description		

Using the Channel Configuration Pane

1. In the Destination Device Name field, click the ... **button**.
The Discovered Devices screen displays.

2. Expand the **tree** to view the destination devices available.
3. Select the **desired device** for the destination.
4. Click **OK**.
The screen closes.
5. Select the **channel** to which the device connects.

**Notice!**

Be sure to configure the DBP channel to the configured ODIN channel. For example, if ODIN channel 5 is configured for DBP channel 1, then DBP channel 1 should be configured to ODIN channel 5.

6. (Optional) Enter the **channel description**.

Using the Device Configuration Pane

1. (Optional) Enter a **description** for the device.
2. Send the **changes** to the device.

Refer to

- *Accept a connection offer on DBP, page 19*

6.5

Create connections using AZedit

6.5.1

Configure OMS/ODIN to make a connection offer

Ethernet configuration must be done before an OMNEO channel connection is made.

To **configure an OMS/ODIN to make a connection offer**, do the following:

1. On the KP screen, select the **port (2)** to configure the connection.

**Notice!**

If configuring OMS to make connections, you must select an OMNEO port from the Port Alpha fields (2).

2. Click the **Edit button (1)**.
The Keypanel/Port Configuration screen opens.

3. Enter the **Device Name** of the device to which you want to connect. Use the browse button to open the available devices screen to select a device.
The IP Address of the device automatically populates the IP Address field.
4. Select the **Device Type** to which you want to connect.
5. Select the **OMNEO channel** on which to communicate.
6. Select the **Latency** of the connection.

**Notice!**

DBP supports a minimum latency of 2ms.

6.5.2

Configure an OMI card to make a connection offer

To **configure an OMI card to make a connection offer**, do the following:

1. From the status menu in AZedit, select **I/O Cards**.
The I/O Card Status screen appears showing a list of installed cards.
2. Right-click the desired **OMI card**.
3. Select **OMNEO Configuration**.
The OMNEO Configuration screen appears.

- From the Local Channel drop down menu, select the **channel** to use to communicate across the network.



Notice!

Available channels appear with an asterisk next to them.

- Enter the **name of the device** to which you want to make a connection.
OR
Select the **Browse button** to select from a list of devices.
- Enter the **IP address of the device** to which you want to make a connection offer.
This field auto-populates when you select the device name.
- From the Partner Device Type drop down menu, select the **type of device** to which the OMI card connects. This field auto-populates when you select the device name.
- From the Partner Channel drop down menu, select the **channel** on the partner device to which you want to make a connection offer.
- Click **Apply**.
Apply sends the changes to each of the cards for which you have made changes.
OR
Click **Cancel** to discard all changes.

7 Modes of operation

DBP has two modes of operation, PL (Party Line) mode and Keypanel mode. When the belt pack connects to an OMS, it runs in PL mode. When it connects to an ODIN or an OMI card in an ADAM or ADAM M frame, it runs in Keypanel mode.

7.1 PL Mode

The DBP operates in PL mode when it connects to an OMS system. In PL mode, the display screen shows Party Line assignments, Relay, or UPL Resource assignments. You can make PL assignments via DBP, while you use AZedit to make Relay or UPL Resource assignments.



Figure 7.1: Party Line Mode

To change PL assignments, refer to *Setup | Key Assignments, page 57*.

7.2 Keypanel Mode

The DBP operates in keypanel mode when it connects to an ODIN or an OMI card in an ADAM or ADAM-M frame. In keypanel mode, the DBP supports any key assignment type supported by the intercom.

























Figure 7.2: Keypanel Mode

To change key assignments in keypanel mode, refer to *Setup | Key Assignments, page 57*.

8 Basic Operation

8.1 Main screen icons

The main screen icons help you get a snapshot of connection states of the DBP.

	DBP connected to intercom
	DBP connected to intercom, but muted
	DBP expecting a connection
	DBP has offers
	Aux connected to the intercom
	Aux connected to the intercom, but muted
	Aux expecting a connection
	Aux has offers
	XLR headset connected
	XLR headset error
	3.5mm headset connected
	3.5mm headset error
	Bluetooth headset connected
	Bluetooth headset error
	Mic status normal
	Mic status muted
	Hot mic enabled
	Low vibration call alert active
	High vibration call alert active
	Bluetooth headset, nothing paired
	Bluetooth headset paired, not present
	Bluetooth headset paired, present, not selected

	Bluetooth headset paired, present, and selected
	Bluetooth headset paired, selected, not present
	Bluetooth device, nothing paired
	Bluetooth device paired, not present
	Bluetooth device paired, present, not selected
	Bluetooth device paired, present, and selected
	Bluetooth device paired, selected, not present
	New CWW entries are present
	Existing CWW entries are present

Table 8.1: Display Status Icons

8.2 Navigation basics

There are five basic buttons to navigate through the Digital Belt Pack menu system.

A/C shaft encoder ¹	<p>Controls the master volume and by pressing the shaft encoder, toggles the control to Key A or Key C listen volume.</p> <p>Scrolls through the menu items when in a menu or sub-menu.</p> <p>In most situations, pressing the A/C shaft encoder button behaves the same as pressing the CLR/BACK button. Some exceptions to this are when editing a device name and when deleting a character.</p> <p>Used to edit a menu item value/state in an active menu.</p> <p>Exits the current menu item or aborts editing of the highlighted menu item (applies to the shaft encoder as a push button).</p>
B/D shaft encoder ¹	<p>Controls the master volume and by pressing the shaft encoder, toggles the control to Key B or Key D listen volume.</p> <p>Controls Key B and Key D volume.</p> <p>Scrolls through the menu items when in a menu or sub-menu.</p> <p>In most situations, pressing the B/D shaft encoder button behaves the same as pressing the SEL/MENU button. Some exceptions to this are when editing a device name and when inserting a character.</p>

	Enters a sub-menu, activates a menu item, or saves changes to an activated menu item (applies to the shaft encoder as a push button).
SEL/MENU button	Enters the menu from the home screen. Selects a sub-menu from the main menu. Activates the selected menu item. Saves changes in an activated menu item and deactivates the menu item. Dismisses popup notifications. Confirms choice in some popup dialogs.
CLR/BACK button	Shows or hides the CWW window from the home screen. Exits the menu (or moves back one level in the menu if in a sub-menu). Discards changes in an activated menu item. Dismisses popup notifications. Declines/aborts choice in some popup dialogs. Displays the Connection state.
CALL button	Generates outgoing CALL signals.

1. In some activated menu items, the A/C and B/D shaft encoders behave differently. Specifically, when editing device/domain names or IP addresses, the A/C shaft encoder moves the cursor between letters or octets and the B/D shaft encoder change the value of the currently highlighted letter/octet. Similarly, in the Mixer menu, the A/C shaft encoder selects the input to modify for the currently active output, and the B/D shaft encoder enables/disables the mix from the selected input to the active output.

To **enter and navigate the menu structure**, do the following:

1. Press the **SEL/MENU button**.
The main menu structure appears in the display.
2. Rotate either **shaft encoder** to navigate through the menu.
3. Click the **B/D shaft encoder** to select a menu item
OR
Press the **SEL/MENU button** to select a menu item.
4. Click the **A/C shaft encoder** to back out of a menu
OR
Press the **CLR/BACK button** to back out of a menu.

8.3

Hot keys

HOME screen:		
	Press and release the SEL/MENU button	Enter menu mode.
	Press and release the CLR/BACK button	Displays the CWW. Press CLR/BACK to dismiss the CWW.
	Press and hold the CALL button (in PL Mode)	Initiates an outgoing CALL signal for whichever Talk keys are currently on with PL assignments. The CALL signal lasts until you release the CALL button







	Press and hold the CLR/BACK button (in Keypanel Mode)	Acts as SHIFT. Press any TALK keys while holding the SHIFT key toggles the key to a LISTEN state. Release the CLR/Back button to exit SHIFT mode.
	Press and hold the CLR/BACK button and then press and release the CALL button.	Displays the Connection status. The Connected popup displays if you have a connection to an intercom and shows the port number and alpha for the connection. The Disconnected popup displays if you do not have a connection to the intercom and it shows the device name and IP address. Press the CLR/BACK or SEL/MENU button to exit.
	While a phone call is active, press and hold the CLR/BACK button and then press and hold the CALL button.	Displays the Phone Call Management popup window. Use the shaft encoders to select an option and then press the SEL/MENU button to activate that option. There are two options, Hang Up and To Intercom. To Intercom is a mixer toggle on/off option. Press CLR/BACK to dismiss.
	Press and hold the CLR/BACK button and then press and hold the SEL/MENU button until the lock icon appears (or disappears if starting from the lockout state)	Toggle control lockout on and off. To unlock, repeat the sequence.
	Press and hold the CLR/BACK button and then press and release one of the Master Volume Controllers	Toggle between display off, display dim, and display dark modes. You can also use the Display Mode menu item in the Display menu to make these changes.
	While Key Volume is active, press and hold one of the shaft encoder buttons until the volume mutes (or unmutes if starting from the mute state). NOTE: Use the A/C shaft encoder to mute TALK key A or TALK key C; use the B/D shaft encoder to mute TALK key B or TALK key D.	The key assignment is muted. To unmute the key, repeat the sequence.

Receiving an incoming call signal:		
	Pressing the TALK key cancels the CALL beep and vibration.	If the TALK key is on, it stays on when you release the TALK button. If the TALK key is not on, it turns on and stays on if you let go within the latching period.
MENU mode:		
	Press and release the CLR/BACK button with menu highlighted	Go back one level (exits the MENU if at the top level).
	Press and release the CLR/BACK button with widget highlighted	Aborts all changes made and moves the highlight back to the menu
	Press and hold the CLR/BACK button	Exits the menu structure (aborts any widget change in process)
	Press and release the MENU/SEL key (with a menu item highlighted)	Invokes the highlighted menu item (may go to a lower-level menu, or activate the widget associated with the highlighted menu item).
	Press and release the MENU/SEL key (with a widget highlighted)	Deactivates the widget (moves highlight back to menu item) and saves the current widget state (as current operating mode)
	Press the A/C shaft encoder button	Go back one level (exits the MENU if at the top level). Behaves the same as the CLR/BACK button in most situations.
	Press the B/D shaft encoder button	Invokes the highlighted menu item (may go to a lower-level menu, or activate the widget associated with the highlighted menu item). Behaves the same as the SEL/MENU button in most situations.
	Rotating either shaft encoder (with a menu item highlighted)	Moves the menu item highlight to the next or previous menu item.
	Rotating either shaft encoder (with a widget highlighted)	Adjusts/edits the data represented by the widget. For many widget types, A/C shaft encoder and B/D shaft encoder are treated the same. For example, adjusting a gain or brightness, or selecting a value in a spin control, or changing the state of an binary or tri-state widget, can all be done by rotating either shaft encoder

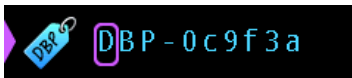
		<p>For a few widget types, the A/C shaft encoder and the B/D shaft encoder do different actions.</p> <p>For example, while editing an IP address or a text field (like the device name or domain), the A/C shaft encoder moves the “cursor” between octets or characters, and the B/D shaft encoder adjusts the value/character at the cursor position. The same is true for the Mixer widget, where the A/C shaft encoder would select the input source and the B/D shaft encoder changes the state of the mix.</p>
	Pressing and releasing the CALL button while in the menu	Behaves the same as when you are on the Home screen (for example, send CALL signal or activate SHIFT mode, depending on whether the DBP is in PL mode or KP mode).
	Press and hold the CLR/BACK button, and then press and release the SEL/MENU button	Jump to last viewed widget

8.4

UI controls

UI Control	Type	Description
	Input field	<p>The A/C shaft encoder and the B/D shaft encoder do different actions.</p> <p>For example, while editing an IP address or a text field (like the device name or domain), the A/C shaft encoder moves the “cursor” between octets or characters, and B/D shaft encoder adjusts the value/character at the cursor position.</p>
	Binary choice	Use either shaft encoder to choose between two options.
	Tri-choice	Use either shaft encoder to switch between three options.
	Spinner	Use either shaft encoder to scroll through the list of options.
	Bar graph	Use either shaft encoder to increase or decrease the setting.
	Mixer type	The A/C shaft encoder and the B/D shaft encoder do different actions.

UI Control	Type	Description
		For example, while configuring Mixer settings, the A/C shaft encoder would select the input source and the B/D shaft encoder changes the state of the mix. NOTE: You can select more than one option simultaneously.

8.5 Volume adjustment

There are two volume adjustments available on the belt pack: Master Volume and key Listen volume.

8.5.1 Master volume adjustment

To **adjust the master volume**, do the following:

- ▶ Click or rotate **either shaft encoder**.
 A volume bar appears on the display screen. The volume bar increases or decreases depending on the adjustment made. The belt pack exits volume adjustment mode after a few seconds of inactivity.

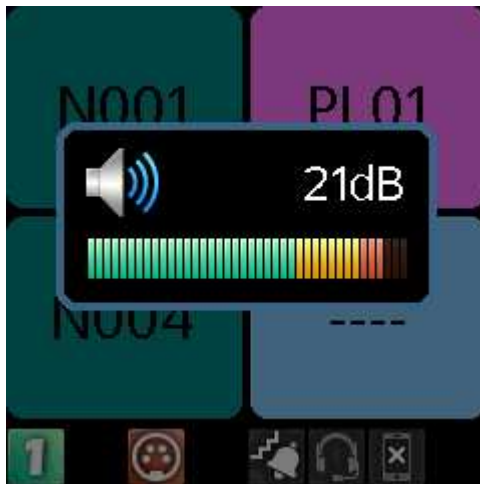

If the Master Volume is muted, the home screen displays a speaker mute symbol.

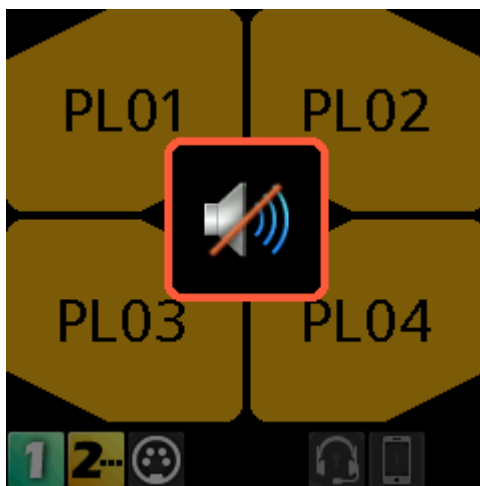

8.5.2 Individual key volume adjustment

To **adjust individual listen volumes for Key A and Key C**, do the following:

1. Click either **shaft encoder**.
The master volume activates.
2. Click the **A/C shaft encoder once for key A and twice for key C**.
The listen volume adjustment for the key activates and a volume bar appears on the key.

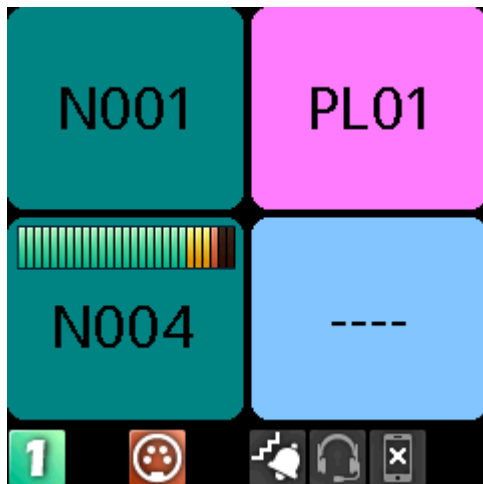

3. Rotate the **A/C shaft encoder** to adjust the volume.
The volume bar increases or decreases depending on the adjustment made. The belt pack exits volume adjustment mode after five seconds of inactivity.



Notice!

To adjust the volume for key B and D, follow the same instructions for key A and C, except use the B/D shaft encoder.

8.5.3 Adjust volume for OMNEO 2, Bluetooth, and 3.5mm input volumes

To **adjust the volume for OMNEO 2, Bluetooth, and 3.5mm input volumes**, do the following:

1. On the main screen, press and hold the **SHIFT button** while rotating **either shaft encoder**.
The OMNEO 2 input volume appears.
2. Rotate the **shaft encoder** to the desired level.
3. While in the OMNEO 2 input volume, press and release either **shaft encoder** to toggle to the Bluetooth or 3.5mm input volume.
4. Rotate the **shaft encoder** to the desired level.

8.5.4 Mute a PL key assignment

In PL mode, listen is always on. You can mute PL assignments so only one PL assignment is heard.

To **mute an individual PL key**, do the following:

1. Click either **shaft encoder**.
The master volume activates.

- Click the **A/C shaft encoder once for key A and twice for key C.**
The listen volume adjustment for the key activates and a volume bar appears on the key.
- Click and hold the **A/C shaft encoder** until Muted appears on the individual PL key assignment.



- Repeat **steps 1 through 3** to mute other key assignments.
- NOTE:** To unmute a key, repeat the same process for muting a key.

8.5.5 Adjust Matrix In level in AZedit

To **adjust the Matrix In level in AZedit**, do the following:

- In AZedit, select the **port** of the device.
- Click the **Keypanel Configuration icon**.

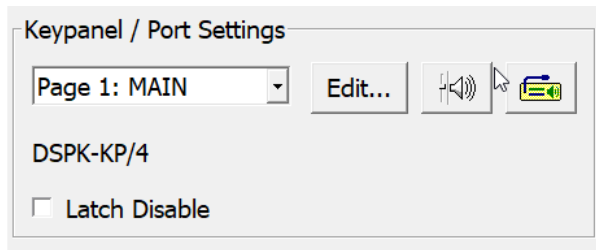

- Adjust the **Input Volume for Matrix In**.

Keypanel Configuration

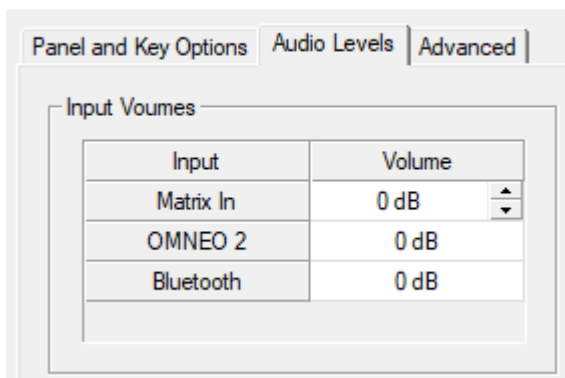

8.6 Call Signaling

Use **Call Signaling** to alert party line users that there is incoming audio on the line. By default, call signaling uses the flashing call button to alert party line users. However, enabling call alerts allows a beep or a vibration to signal incoming audio on the line. For more information on call alerts, see *Call Alerts, page 85*.

For example, a producer starts talking to a camera operator on PL01 and the camera operator does not hear the producer because they are not wearing their headset. The producer can send a call signal alert to PL01 that generates a call beep or vibration (if enabled) that would let the camera operator know someone is talking and to put their headset on.

To **send a call signal**, do the following:

1. Press and hold, or latch on the **talk keys** for which you want to send the signal.
2. Press the **CALL** button.
The red talk key indicators turn blue and the call signal icon shows in the center of the display.



Notice!

The call signal generates for as long as you hold the CALL button and the talk keys are still on.

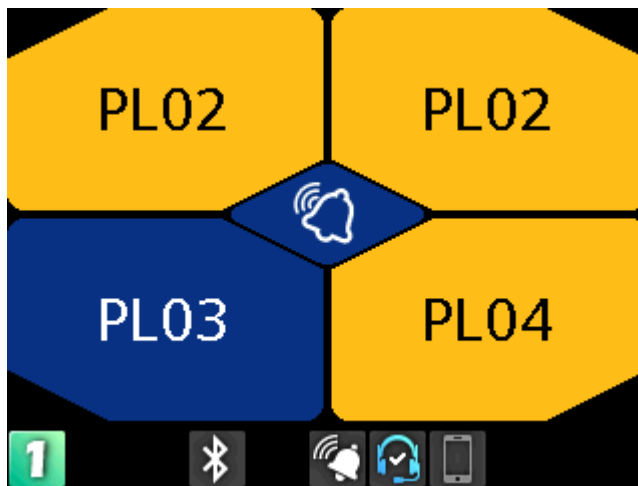

Figure 8.1: Call Signal - PL Mode



Notice!

In KP mode, only the key tile tallies to alert the user of an incoming call.

3. Release the **CALL button** or turn off the **talk keys** to end the call signal.

8.7 Talk and Listen

The Talk and Listen functions on the DBP act like any traditional keypanel.

Talk

There are four configurable modes of talk operation: Latching, Momentary, Always On, and Always Off. For detailed descriptions about the modes of operation and how to configure Talk operation, see *Setup | Key Modes, page 66*.

To **talk**, do the following:

1. Press and hold, or latch on, the **key** with the assignment to which you want to talk.
2. Release the **key**, or tap it to unlatch it, to stop talking.

Listen

Listen key operation is the same as talk key operation, except that listen keys are always latching and you need to press and hold the CALL/SHIFT button so that A - D key presses are treated as listen key presses, not talk key presses.

Access to listen key states using the CALL/SHIFT button is only available in KP mode.

In PL mode, the listen keys are Always On (for PL assignments) and Always Off (for any other type of assignment). For instruction on how to mute PL assignments on the belt pack, see *Volume adjustment, page 33*.

To **listen**, do the following:

1. Press and hold the **CALL button**.
2. Tap the **key** for which you want to change the listen key state.

8.8 Call waiting window



Notice!

Do not confuse call signaling with incoming calls. Party lines use call signaling to notify users that someone is trying to get their attention. Incoming calls are direct point-to-point calls from another panel to the belt pack.

Use the **CWW** (Call Waiting Window) to manage multiple incoming calls to the belt pack. The CWW displays three calls at a time with a scroll bar appearing if there are more calls (up to nine) in the list.

A popup window appears on the HOME screen that alerts the user of an incoming CWW call. Press CLR/BACK to dismiss the notification or press SEL/MENU to show the full CWW.



Reply to a CWW call

To **reply to a CWW call**, do the following:

1. On the home screen, press the **CLR/BACK button**.
The CWW window appears.



2. Press **REPLY (Key D)** to answer the call.
The REPLY key and the caller lights green.



Remove an entry from the CWW

To **remove an entry from the CWW**, do the following:

1. While the CWW is open, press **CLEAR (Key C)**.
The CLEAR button lights red and the call disappears from the list.



Show the CWW

To **show the CWW**, do the following:

- ▶ On the home screen, press the **CLR/BACK button**.
The CWW window appears.

Scroll and select a call in the CWW

To **scroll and select a call in the CWW**, do the following:

- ▶ While the CWW is visible, with calls, rotate the **either shaft encoder** to highlight an entry.

Hide the CWW

To **hide the CWW list**, do the following:

- ▶ While the CWW window is visible, press the **CLR/BACK button**.
The CWW window closes.

8.9

Bluetooth

The DBP supports Bluetooth technology allowing connections to Bluetooth enabled devices, if desired. To use Bluetooth on the DBP, the device must have an approved Bluetooth dongle installed. For more information, see *Install the Bluetooth dongle, page 16*. The Bluetooth menu item appears grey when the dongle is not present in the device.



Figure 8.2: Bluetooth dongle not installed

When the dongle is present, the icon turns blue and access to the menu is granted.



Figure 8.3: Bluetooth dongle installed

For instructions on how to pair and connect the Bluetooth device, see *Bluetooth*, page 87

8.9.1

Answer a phone call via Bluetooth

To **answer a phone call via Bluetooth**, do the following:

When a call comes into the belt pack via a Bluetooth device, a popup notification appears.

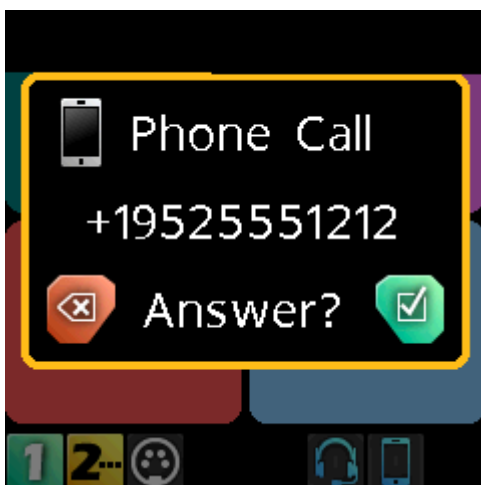

1. Press the **SEL/MENU button** to answer the call or press the **CLR/BACK button** to ignore the call.

A Call Connected popup notification appears.

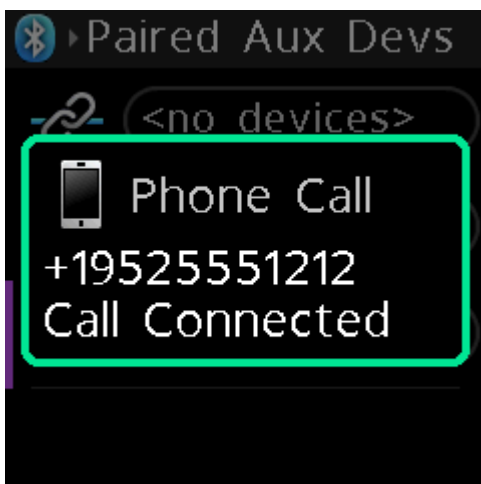

2. Press the **SEL/MENU button again** to display the call management screen.



3. Press the **SEL/MENU button** to hang up.
A call ended popup notification appears.

8.9.2 Phone call management window

Use the **Phone Call Management** window to patch incoming calls through to the intercom or hang up the phone.

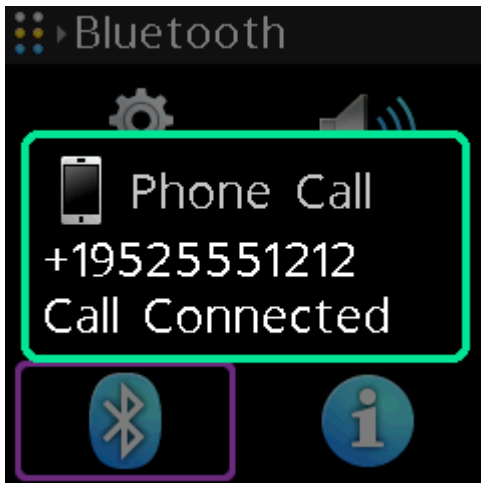

Figure 8.4: Call Management Screen

8.9.3 Patch a phone call to the Intercom

To **patch a phone call to the intercom**, do the following:

When a phone call comes into the belt pack via a Bluetooth device, a popup screen appears.



1. Press the **SEL/MENU** button.
The Phone Call Management window appears.



Notice!

Also access the Phone Call Management window by pressing and holding the CLR/BACK button and then pressing and holding the CALL button while a phone call is active.



2. Rotate either **shaft encoder** to navigate to To Intercom.
3. Press the **SEL/MENU**.
The audio routes to the intercom.



Notice!

To Intercom is a toggled state. Turn it on and off by pressing the SEL/MENU button while on this item.



Notice!

When you select To Intercom the mic audio and the phone audio go to the intercom; and, anything heard from the intercom is heard on the phone. When you do not select To Intercom, you only hear the Bluetooth phone audio in the headset, and any audio from the microphone goes to the connected phone only.

8.10 Upgrade firmware

There are two ways to upgrade the DBP firmware; using the Firmware Upload Tool or using AZedit.

ODIN	1.4.0 or later
OMI	6.7.0 or later
AZedit	5.6.0 or later
IPedit	3.7.0 or later
FWUT (Firmware Upload Tool)	6.20 or later

Table 8.2: Software requirement

To **upgrade the firmware using the Firmware Upload Tool**, do the following:

1. Open the **Firmware Upload Tool**.
2. From the File menu, select **Options**.
The Firmware Upload Tool Options window opens.

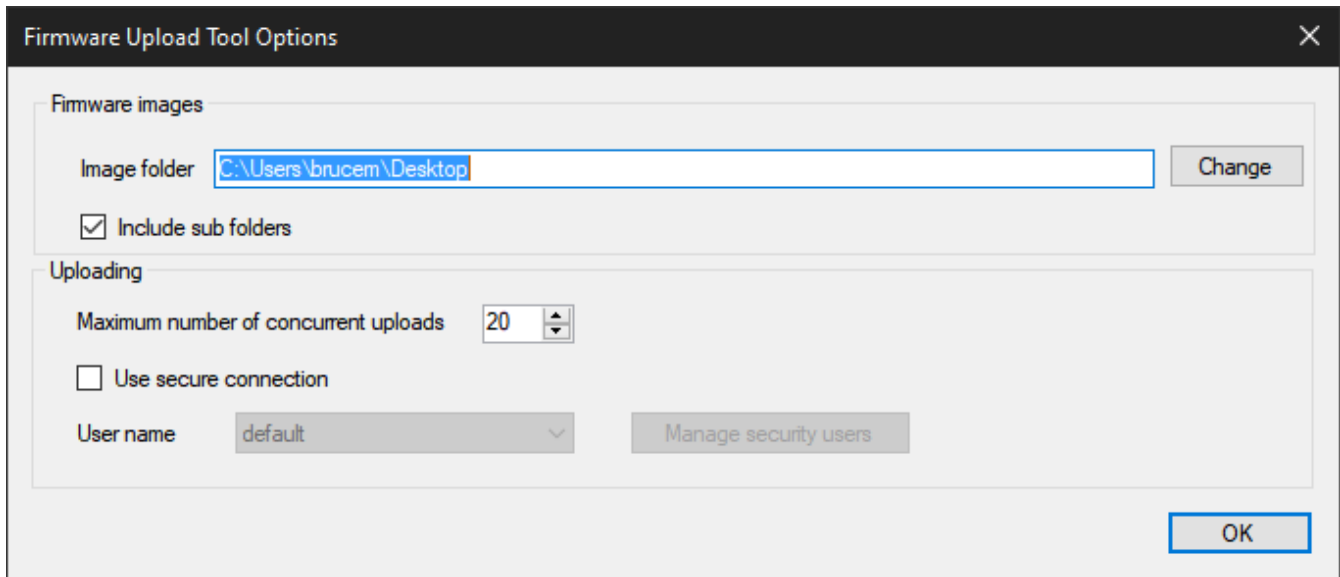

3. Click the **Change button**.
A network folder opens.
4. Navigate to the **folder** where the firmware files resides.
5. Click the **OK button**.
The Image Folder field populates with the file path.
6. Click the **OK button**.
The Firmware Upload Tool Options window closes.
7. From the DBP page, select the **device** to update.

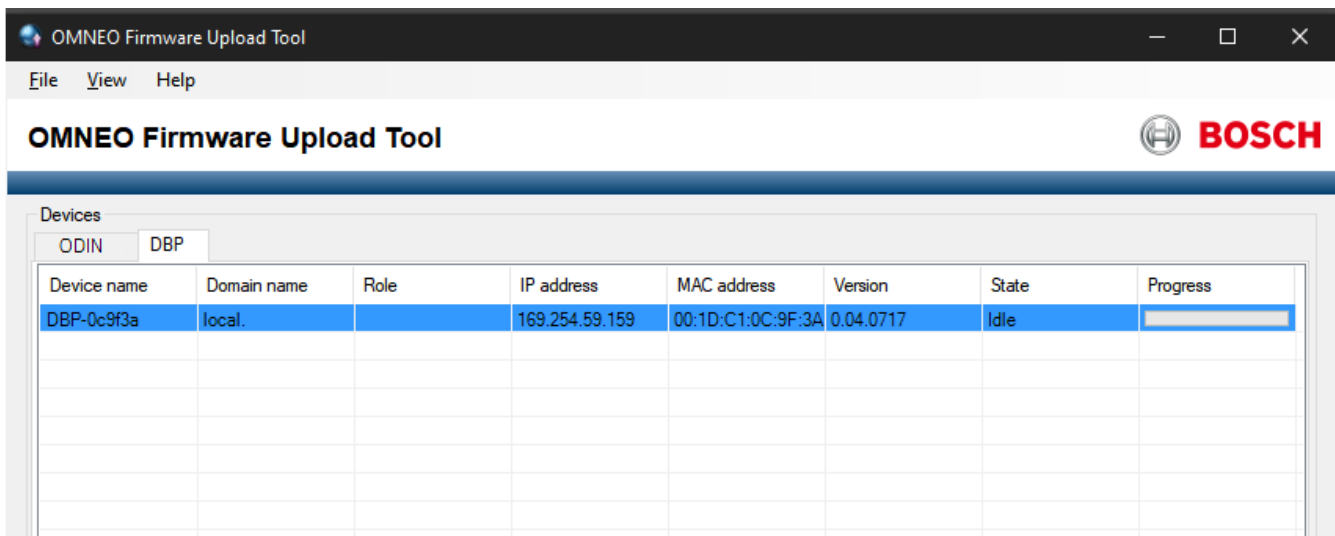

8. Click the **Upload button**.
The Select firmware for upload window opens.

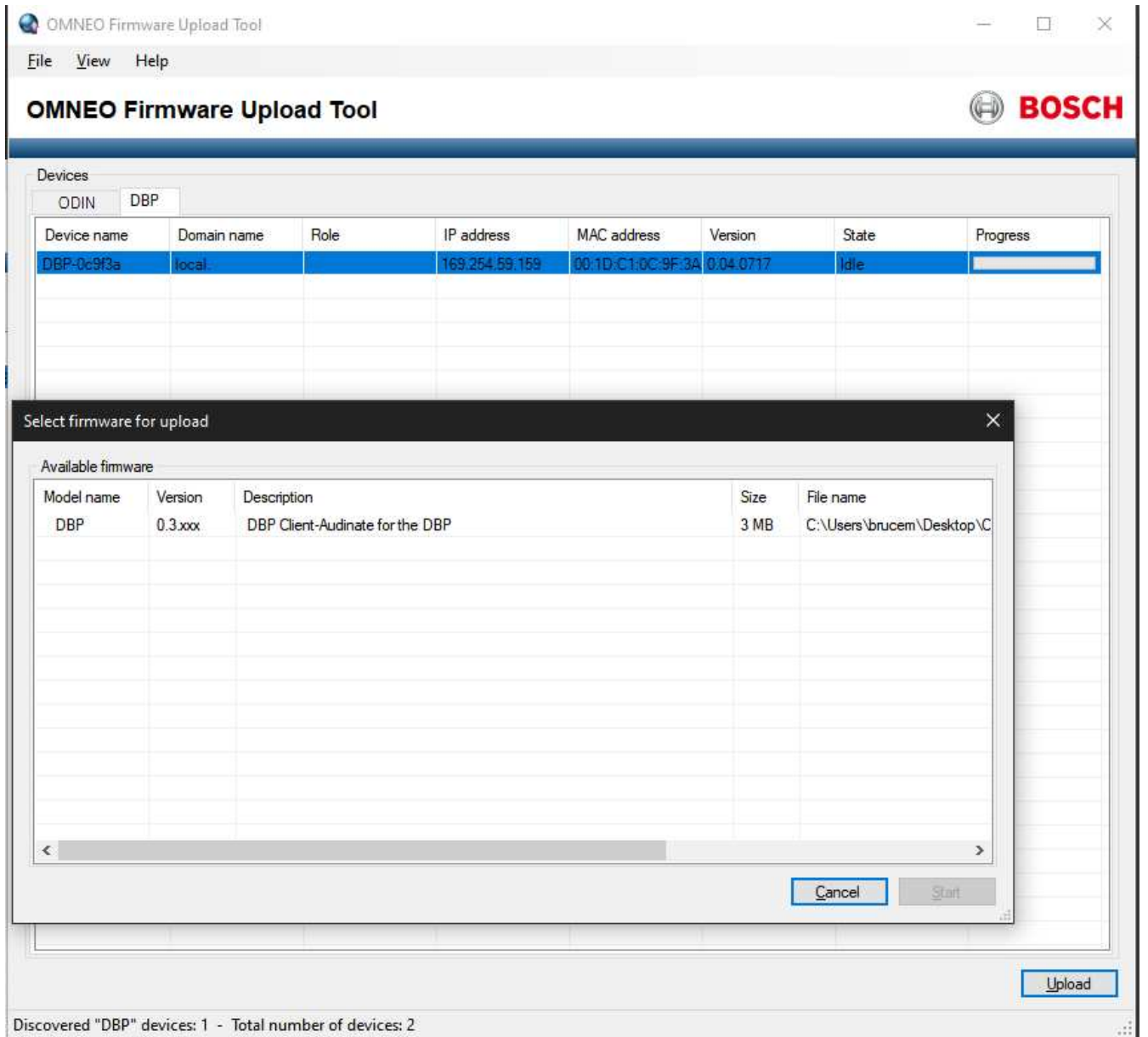

9. Select the **firmware** to upload.

10. Click the **Start button**.

The Select firmware for upload window closes. The progression bar next to the device shows the download progress. Once the update is complete, the device reboots automatically.

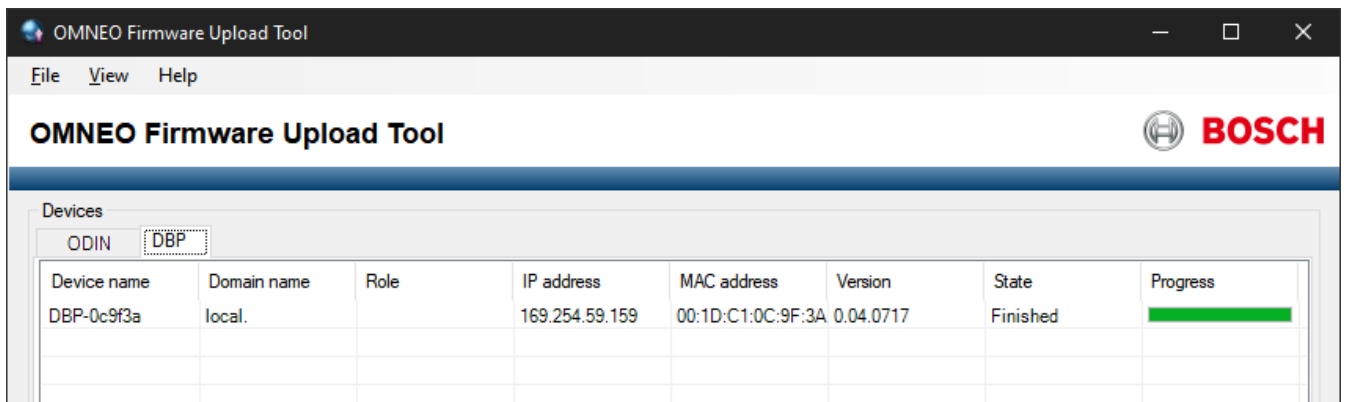

To **upgrade the firmware using AZedit**, do the following:

1. Open **AZedit**.
2. From the Status menu, select **Software Versions | Port**.
3. Select the **port** to update.
Select multiple ports by holding the CTRL key down while making selections.
4. Right-click the **highlighted selections**.
A popup menu appears.

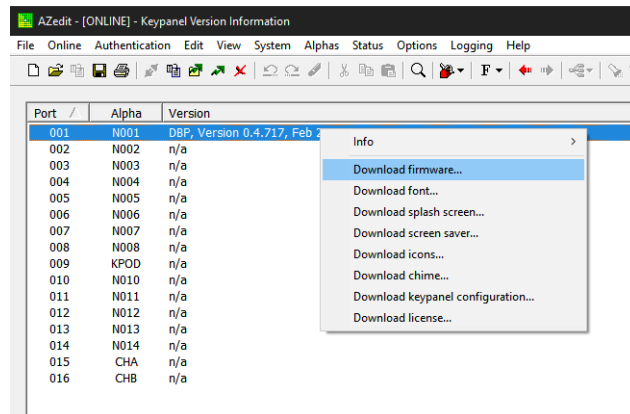

5. Select **Download Firmware...**
The Firmware Download window appears.
6. Click the **Browse button**.
7. Navigate to the **folder** where the firmware files resides.
8. Click **Open**.
The Download Device Firmware window opens.
9. Click **Begin Download**.
The download begins.

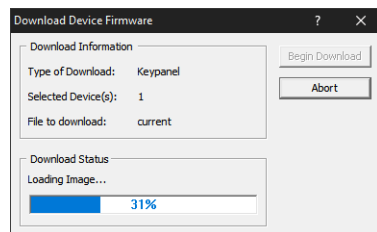

10. Verify the **download progress** on the device.
Once the download is complete, the device reboots automatically.

8.11 Download screen saver images or splash screen images

When creating screen saver images or splash screens, use the following parameters:

Screen saver images can be a maximum of 120 pixels x 120 pixels and a minimum of 16 x 16. Whereas, splash screens should be 240x240 pixels, to fill the whole screen. The image centers on the screen if it is smaller than the 240 pixels.

Supported file types are: .bmp, .gif, .jpg, .png, and .tif.

To **download a screen saver or a splash screen image to the device**, do the following:

1. Open **AZedit**.
2. Select **Software Versions | Keypanel** from the Status menu.
The Keypanel Version Information screen displays.
3. Highlight the **device** to be updated.

- Right-click the **highlighted selections**.

A popup menu displays.

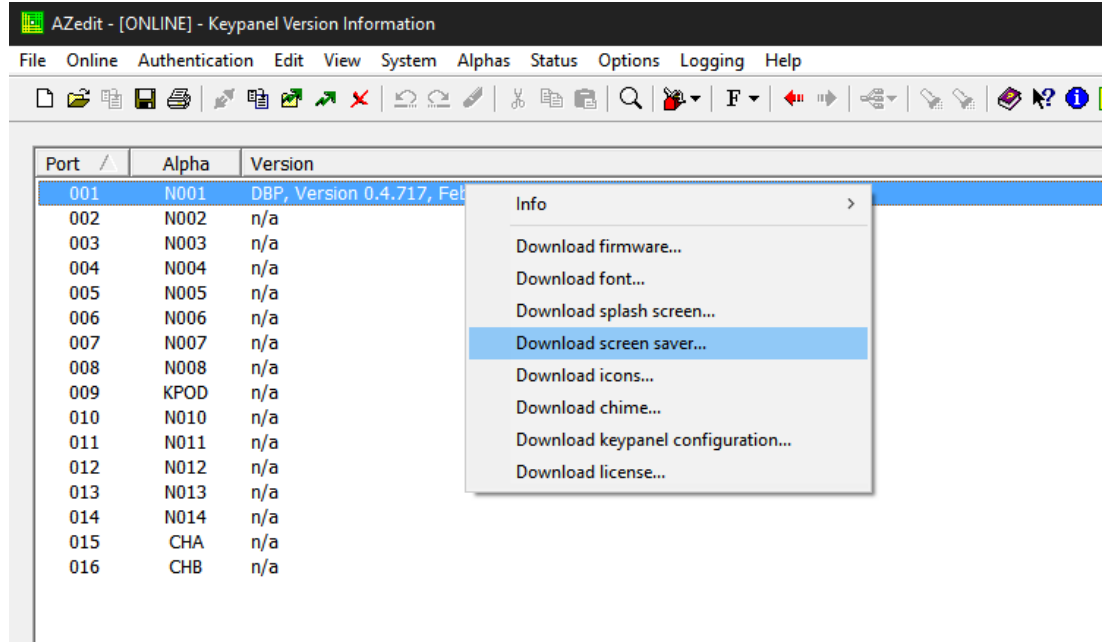

- Select **Download screen saver...** or **Download splash screen...** .

A Windows explorer screen appears.

- Navigate to the **desired file**.

- Click **Open**.

The Download Screen Saver File screen opens.

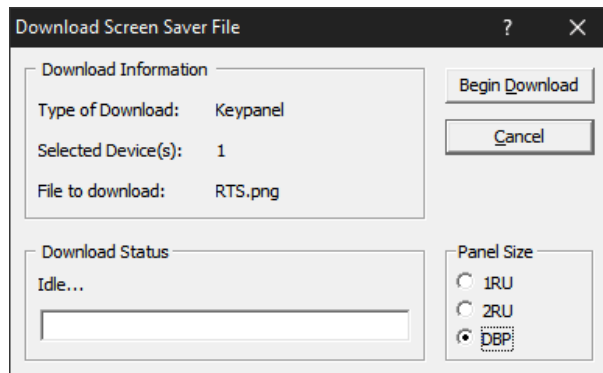

- Select the **DBP radio button** from the Panel Size group box.

- Click **Begin Download**.

The download begins. A progression bar appears to show the progress of the download. Once complete, a success message shows.

- Click **OK**.

The message closes. The file is updated.

8.12 Priority Call Volume Control

Use the **Priority Call Volume Control** to mark a device as a priority caller. When a priority caller talks to another keypanel, a minimum crosspoint volume (configurable in AZedit) is enforced for the duration of the call to ensure the caller is heard, even if the target device listen is set to a lower level.

In addition, the system applies a minimum of -6dB on the speaker and headset of the target device receiving the priority call. This ensures the priority caller is heard even if the target device's headset and speaker volume is turned down. Once the call is over, the previous speaker, headset, and crosspoint volumes revert to the original settings.

When the device is the target of a priority call, the CWW icon in the status bar displays in orange and indicates a priority call is in progress.

NOTE: Priority calls never lower volume levels. Volume levels only increase to the configured settings for the duration of the call.

To **configure priority call volume**, do the following:

1. On the Keypanels/Ports screen in AZedit, select the **port** to set which priority call volume.
2. Click the **Edit** button.
3. Click the **Advanced** tab.

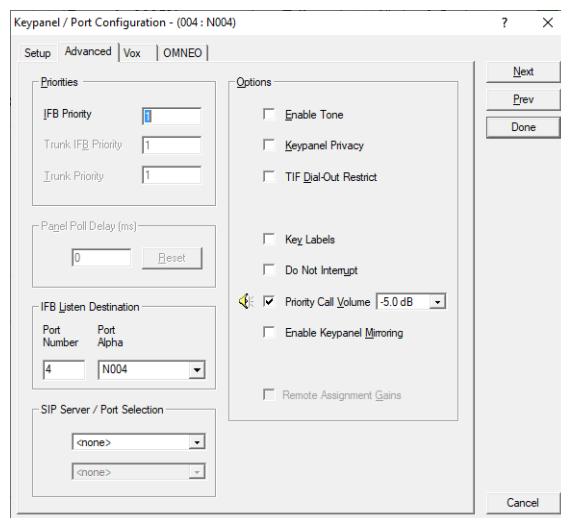

4. Select the **Priority Call Volume** check box.
5. From the drop down box, select the **minimum crosspoint volume level** for the priority caller.
6. Click **Apply**.
7. Send the **changes** to the intercom.

9 Menu Structure

The main DBP menu structure has six sub-menus, two of which (Setup and Audio) are also main menus with sub-menus:



Figure 9.1: Main Menu

- Setup - Use to configure the network, connection offers, key assignments, service items (such as enabling tone, entering test mode, and performing resets), setting authentication, and configuring key modes.



Notice!

When showing the Setup menu, the network menu is disabled and the context text shows as initializing until the DBP acquires an IP address. Similarly, the Key Assignments menu is disabled and the context text shows Not Connected until the DBP connects to an intercom.

- Audio - Use to configure the headset, microphone, Aux levels, Bluetooth gain levels, OMNEO CH2 levels, and set up audio mixing.
- Call Alerts - Use to configure call alerts, such as call beep and call vibration.
- Information - Displays the versions of firmware the DBP uses.
- Bluetooth - Use to pair, connect, and disconnect Bluetooth devices.
- Display - Use to configure the display such as brightness level, screen saver timeout, and screen flip.

9.1 Setup | Network

Use the **Network** menu to configure the device name, setup DHCP, configure the IP address, Netmask, Gateway, DNS server, the domain name, and view the MAC address.

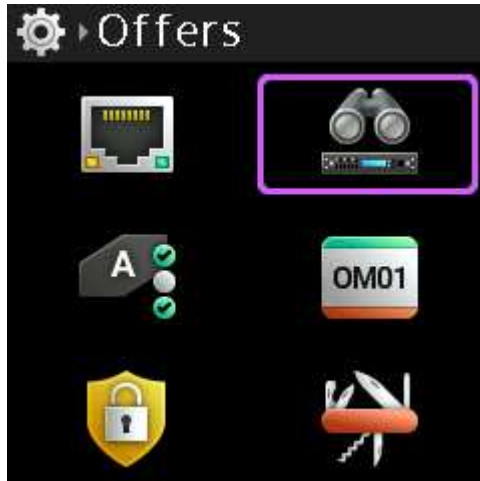

Figure 9.2: Network Menu



Notice!

Any changes made to the network information are not active until leaving the Network menu. A Save prompt appears so that all change approvals occur at the same time.

9.1.1

Device Name

Use the **Device Name** menu item to configure the name of the device.

To **configure the name of the device**, do the following

1. Navigate to the **Device Name menu item** (Setup | Network | Device Name).



2. Press the **SEL/MENU button**.
The first character position highlights.
3. Rotate the **B/D shaft encoder** to scroll through available characters.
OR
Rotate the **A/C shaft encoder** to move to the character for modification.
4. Repeat **step 3** until complete.



Notice!

If you press and hold the A/C shaft encoder, the highlighted character turns red, and then deletes after a couple of seconds. If you release the encoder while it is red, but before it deletes, then nothing happens. If you press and release the shaft encoder quickly, then it behaves like the CLR button and aborts the edit.

Similarly, if you press and hold the B/D shaft encoder, the highlighted character turns white, and a new character inserts after a couple of seconds. If you release the encoder while it is white, before inserting a new character, then nothing happens. If you press and release the shaft encoder quickly, then it behaves like the SEL/MENU button and saves your edits.

5. Press the **SEL/MENU button** to confirm the change, or press the **CLR/BACK button** to abort changes.

9.1.2

DHCP

Use the **DHCP** menu item to enable or disable DHCP on the belt pack.

To **enable or disable DHCP**, do the following:

1. Navigate to the **DHCP menu item** (Setup|Network|DHCP).



2. Press the **SEL/MENU button**.
3. Rotate either **shaft encoder** to toggle between options.
4. Press the **SEL/MENU button** to confirm the change, or press the **CLR/BACK button** to abort changes.

9.1.3

IP Address

Use the **IP Address** menu item to configure the IP Address for the belt pack.

Validation on address fields occur when you try to save them. If an address is invalid, an error prompt displays.



Notice!

Modifications to this field are allowed only when DHCP is disabled.

To **configure the IP Address**, do the following:

1. Navigate to the **IP Address menu item** (Setup | Network | IP Address).

2. Press the **SEL/MENU button**.

The first octet highlights.



3. Rotate the **B/D shaft encoder** to make changes.
OR
Rotate the **A/C shaft encoder** to move to the next octet.
4. Repeat **step 3** until the address is complete.
5. Press the **SEL/MENU button** to confirm the change, or press the **CLR/BACK button** to abort changes.



Notice!

Changes to this menu result in a device reboot.

9.1.4

Netmask

Use the Netmask menu item to configure or change the Netmask address. Netmask addressing subdivides a network, and in turn alleviates heavy network traffic in large systems.

Validation on address fields occur when you try to save them. If an address is invalid, an error prompt displays.



Notice!

Modifications to this field are allowed only when DHCP is disabled.

To **configure the Netmask**, do the following:

1. Navigate to the **Netmask menu item** (Setup | Network | Netmask).
2. Press the **SEL/MENU button**.
The first octet that is not 255 highlights.

**Notice!**

Navigation between octets is automatic depending on which way you rotate the shaft encoder. Rotating the encoder counterclockwise expands the address range, while rotating the encoder clockwise shrinks the address range.

3. Rotate either shaft encoder **clockwise to expand the address range** or **counterclockwise to shrink the address range**.
Once the current octet reaches 255, the focus moves to the next octet.
4. Press the **SEL/MENU button** to confirm the change, or press the **CLR/BACK button** to abort changes.

**Notice!**

Changes to this menu result in a device reboot.

9.1.5

Gateway

Use the **Gateway** menu item to configure the gateway address for the belt pack. Validation on address fields occur when you try to save them. If an address is invalid, an error prompt displays.

**Notice!**

Modifications to this field are allowed only when DHCP is disabled.

To **configure the gateway address**, do the following:

1. Navigate to the **Gateway menu item** (Setup | Network | Gateway).
2. Press the **SEL/MENU button**.
The first octet highlights.



3. Rotate the **B/D shaft encoder** to make changes.
OR
Rotate the **A/C shaft encoder** to move to the next octet.
4. Repeat **step 3** until the address is complete.
5. Press the **SEL/MENU button** to confirm the change, or press the **CLR/BACK button** to abort changes.



Notice!

Changes to this menu result in a device reboot.

9.1.6

DNS Server

Use the **DNS Server** menu item to configure the DNS server address, if applicable. Validation on address fields occur when you try to save them. If an address is invalid, an error prompt displays.

To **configure the DNS server address**, do the following:

1. Navigate to the **DNS server menu item** (Setup | Network | DNS Server).
2. Press the **SEL/MENU button**.
The first octet highlights.



3. Rotate the **B/D shaft encoder** to make changes.
OR
Rotate the **A/C shaft encoder** to move to the next octet.
4. Repeat **step 3** until the address is complete.
5. Press the **SEL/MENU button** to confirm the change, or press the **CLR/BACK button** to abort changes.

**Notice!**

Changes to this menu result in a device reboot.

9.1.7**Domain**

Use the **Domain** menu item to configure the domain to which the belt pack belongs. Validation on address fields occur when you try to save them. If an address is invalid, an error prompt displays.

To **configure the domain**, do the following:

1. Navigate to the **Domain menu item** (Setup | Network | Domain).
2. Press the **SEL/MENU button**.
The first character position highlights.

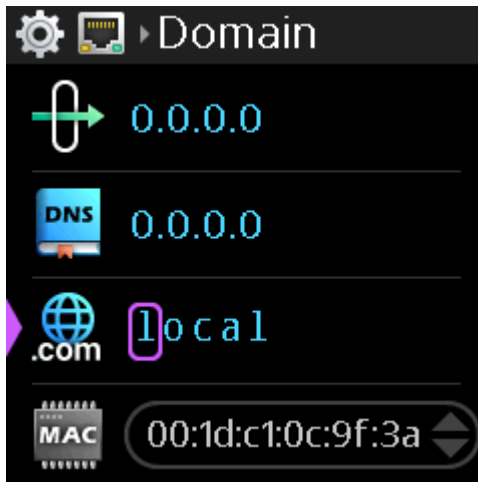

3. Rotate the **B/D shaft encoder** to scroll through available characters.
OR
Rotate the **A/C shaft encoder** to move to the character for modification.
4. Repeat **step 3** until complete.

**Notice!**

If you press and hold the A/C shaft encoder, the highlighted character turns red, and then deletes after a couple of seconds. If you release the encoder while it is red, but before it deletes, then nothing happens. If you press and release the shaft encoder quickly, then it behaves like the CLR button and aborts the edit.

Similarly, if you press and hold the B/D shaft encoder, the highlighted character turns white, and a new character inserts after a couple of seconds. If you release the encoder while it is white, before inserting a new character, then nothing happens. If you press and release the shaft encoder quickly, then it behaves like the SEL/MENU button and saves your edits.

5. Press the **SEL/MENU button** to confirm the change, or press the **CLR/BACK button** to abort changes.

9.1.8**MAC Address**

Use the **MAC Address** menu item to view the MAC address of the digital belt pack. The MAC address field is not editable.

To **display the MAC address**, do the following:

- ▶ Navigate to the **MAC Address menu item** (Setup | Network | MAC Address).
The MAC Address is read only.

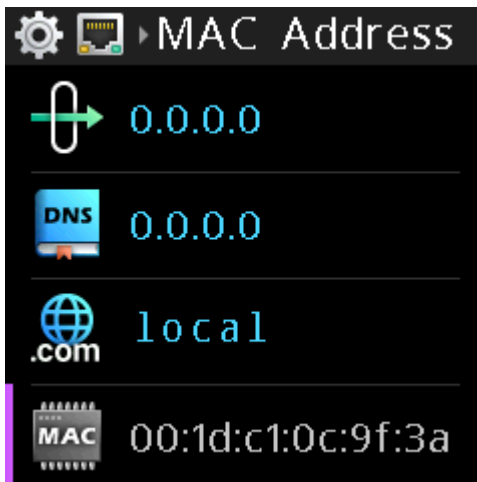
**9.2****Setup | Offers****9.2.1****DBP Offers**

Use the **DBP Offers** menu item to select and accept connection offers from the intercom. DBP offers determine which port on which intercom the DBP is connected as a belt pack and its alpha.

To **accept a DBP Offer**, do the following:

1. Navigate to **the DBP Offers menu item** (Setup | Offers | DBP Offers).
2. Press the **SEL/MENU button**.
The field becomes active.
3. Rotate either **shaft encoder** to scroll through the available offers.

4. Press the **SEL/MENU button** to confirm the change, or press the **CLR/BACK button** to abort changes.

The DBP disconnects from the current offer and reconnects to the newly selected offer.

9.2.2

Aux Offers

Use the **Aux Offers** menu item to configure the DBP to communicate via an intercom port. Aux Offers allows you to connect another device to bring in aux audio to mix in the DBP, or to send audio from the DBP to another device. The Aux channel (OMNEO CH 2) does not have keypad data associated with it. OMNEO, Dante source.

To **accept an Aux Offer**, do the following:

1. Navigate to the **Aux Offers menu item** (Setup | Offers | AUX offers)
2. Press the **SEL/MENU button**.
The field becomes active.
3. Rotate either **shaft encoder** to scroll through the available offers.

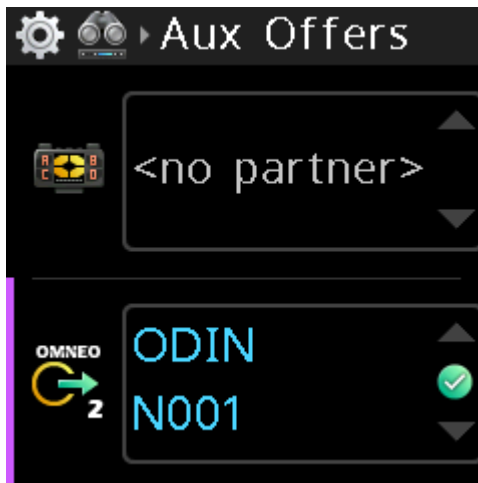

4. Press the **SEL/MENU button** to confirm the change, or press the **CLR/BACK button** to abort changes.

The DBP disconnects from the current offer and reconnects to the newly selected offer.

9.3

Setup | Key Assignments

Use the **Key Assignments** menu item to configure talk key assignments. Depending on what the belt pack connects to, there are two modes of operation, PL Mode and Keypanel Mode. For more information, refer to *Modes of operation*, page 26.

To **configure talk key assignments in PL mode**, do the following:



Notice!

In PL mode, the beltpack supports only PL (party line), RY (relay), and UR (UPL resource) assignment types. RY and UR assignments must be made from AZedit.

1. Navigate to the **Key Assignments menu item** (Setup | Key Assignments).
2. Press the **SEL/MENU button**.
3. Press one of the **A - D buttons** to select the key to modify.
OR
Rotate **either shaft encoder** to navigate to the desired talk key.

**Notice!**

You only need to press SEL/MENU if you use the shaft encoder to select the key. If you press A-D to select the key, it enters the edit mode directly.

4. Press the **SEL/MENU button**.
The talk key LED turns red and the display shows the talk key as scrollable.
5. Rotate **either shaft encoder** to scroll through the available assignments.
If the current assignment is a RY or UR, the scroll list only consists of the current assignment and the NULL assignment (the alpha for the NULL assignment is ----).

**Notice!**

To remove an assignment from a key, assign NULL to the key.

6. Press the **SEL/MENU button** to confirm the selection.

To **configure talk key assignments in keypad mode**, do the following:

1. Navigate to the **Key Assignments menu item** (Setup | Key Assignments).
2. Press the **SEL/MENU button**.
The talk key LED turns red and the display shows the talk key as scrollable.

**Notice!**

You only need to press SEL/MENU if you use the shaft encoder to select the key. If you press A-D to select the key, it enters the edit mode directly.

3. Press one of the **A - D buttons** to select the key to modify.
OR
Rotate **either shaft encoder** to navigate to the desired talk key.
4. Press the **SEL/MENU button**.
The talk key LED turns red and the display shows the talk key as scrollable and the adjacent LED for the adjacent (showing the function type) key turns white.



5. Rotate either **shaft encoder** to scroll through the available assignments.
6. Press the **SEL/MENU button** to confirm the selection.

**Notice!**

To remove an assignment from a key, assign NULL to the key.

To **change the assignment type of a key in keypad mode**, do the following:

1. While changing the assignment of a key, press and hold the **assignment type key**. This moves the scroll highlight to the assignment type. The talk key LED for the assignment type turns red (from white) and the talk key LED for the current assignment (the key being modified) turns white (from red).
2. Rotate either **shaft encoder** to scroll through a list of available assignment types.

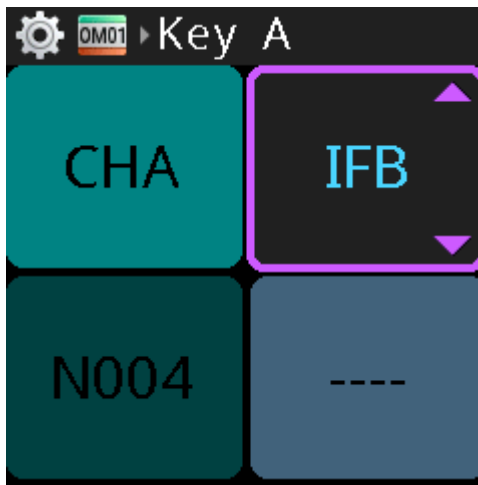

The assignment type changes and a new scrollable list of assignments appears on the talk key button previously selected. If you have not accessed the scroll list for this assignment type before, the DBP asks the intercom for it, and a wait prompt displays until DBP receives the scroll list. If there are no scrollable items available for the selected function type, only the current assignment type and NULL are available.

Refer to

- *Modes of operation, page 26*

9.3.1**Change Setup Page**

Setup Pages allow access to more key assignments than physical keys on the device. This is useful when sharing devices because users can change the setup page to show the key assignments they need.

The device allows up to 15 setup pages per keypad port.

The current active page displays in green text and the inactive pages display in blue text.

To **change setup pages**, do the following:

1. Navigate to the **Key Assignments menu item**.
2. Press the **SEL/MENU button**.
3. Press the **CALL button**.

The Select Setup popup spinner box appears.



4. Rotate either **shaft encoder** to scroll the available options.
5. Press the **SEL/MENU button** to confirm the change, or press the **CLR/BACK button** to abort changes.

9.4 Setup | Service

Use the **Service** menu item to enable or disable the tone setting, enter test mode, perform a user reset, or perform a factory reset.

9.4.1 Tone

Use the **Tone** menu item to enable or disable the 500Hz tone generator. The tone generator transmits a 500Hz tone from the DBP to the intercom which can be used to test the audio paths.

To **enable/disable tone**, do the following:

1. Navigate to the **Tone menu item** (Setup | Service | Tone).
2. Press the **SEL/MENU button**.

The field becomes active.

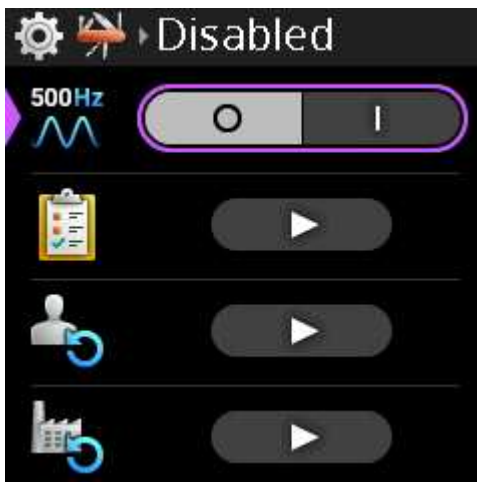

3. Rotate either **shaft encoder** to toggle between choices.
4. Press the **SEL/MENU button** to confirm the change, or press the **CLR/BACK button** to abort changes.

9.4.2

Test Mode

Use the **Test Mode** menu item to check the operation of all keys and displays on the belt pack.

To **enter test mode**, do the following:

1. Navigate to the **Test Mode menu item** (Setup | Service | Test Mode).

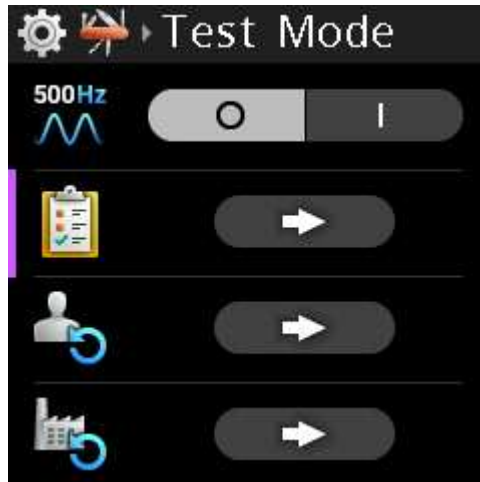

2. Press the **SEL/MENU button**.
The Test Mode screen displays.

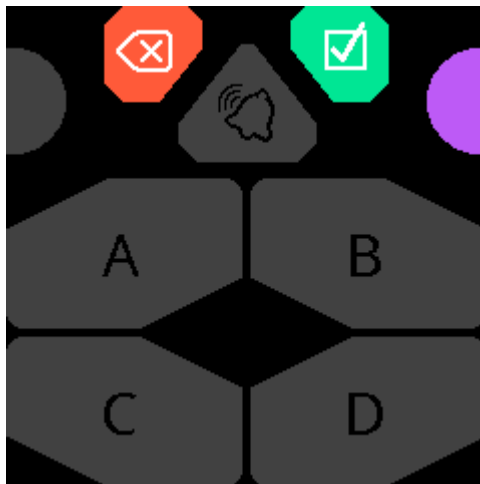

3. Press **each A through D key, CLR/BACK, CALL, and SEL/MENU buttons** to check operation.
The A through D letters light in white and then in red, each time you press the button, and the corresponding LEDs on the physical buttons light in the same color. The icons on the CLR/BACK, CALL, and SEL/MENU keys light white when pressed and the corresponding LEDs on the physical buttons light as well.
4. Press the **shaft encoders** and turn the **shaft encoders**.
The shaft encoder buttons light in magenta when pushed and blue directional arrows appear to indicate the rotational direction when rotating the shaft encoders.

To **exit test mode**, do the following:

- ▶ Press and hold the **CLR/BACK button**.
After 3 seconds, test mode is closed.

9.4.3

User Reset

Use the **User Reset** menu item to reset the device configurations.

To **perform a user reset**, do the following:

1. Navigate to the **User Reset menu item** (Setup | Service | User Reset).



2. Press the **SEL/MENU button**.

A popup message appears to confirm the reset.



3. Press and hold the **SEL/MENU button for 3 seconds**.

A three-second countdown screen appears and then the configuration resets. The DBP does not reboot after a User Reset.

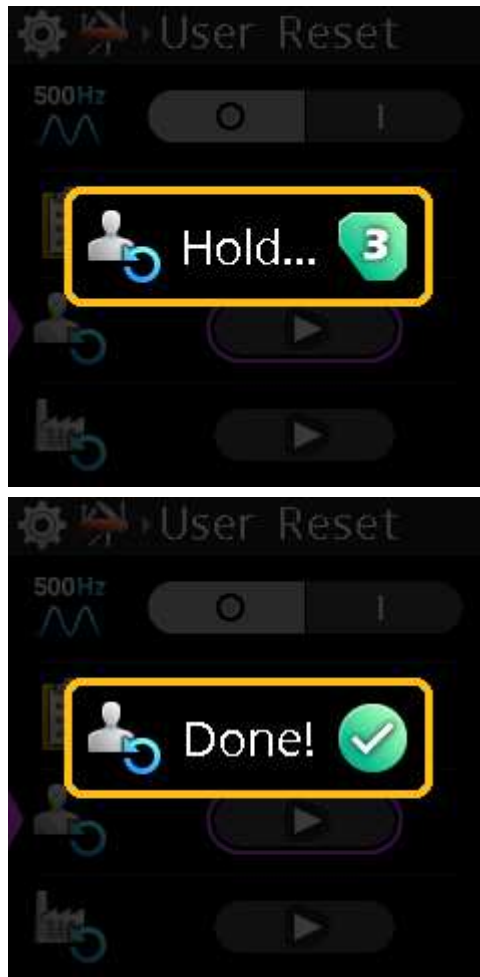

9.4.4

Factory Reset

Use the **Factory Reset** menu item to set the device back to its original factory settings. The factory reset differs from a user reset in that the factory reset deletes all paired Bluetooth devices, any user splash screen or screen saver, any selected offers/partners, and restores the original factory network settings, which includes the device name.

To **perform a factory reset**, do the following:

1. Navigate to the **Factory Reset menu item** (Setup | Service | Factory Reset).



2. Press the **SEL/MENU button**.
The Factory Reset confirmation message appears.

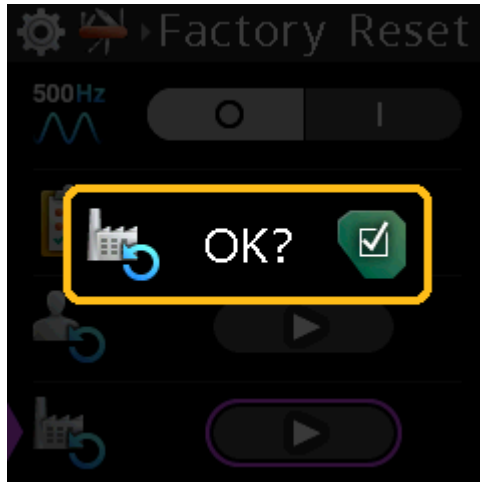

3. Press and hold the **SEL/MENU button for three seconds**.
A three-second countdown message appears and then the belt pack performs a factory reset and then reboots.



9.5 Setup | Authentication

Use the **Authentication menu** to enable or disable PIN entry and set the PIN entry security. When authentication is active, entry of a PIN code is necessary to access the menu structure.



Notice!

Confirmation of the PIN, if Authentication is enabled, occurs upon exiting the menu or the PIN is changed.

9.5.1 Require PIN

By default, the DBP does not have PIN entry security enabled.

To **enable PIN entry**, do the following:

1. Navigate to the **Authentication menu item** (Setup | Authentication).
2. Press the **SEL/MENU button**.

3. Navigate to **the Require PIN menu item**.
4. Press the **SEL/MENU button**.
The field becomes active.

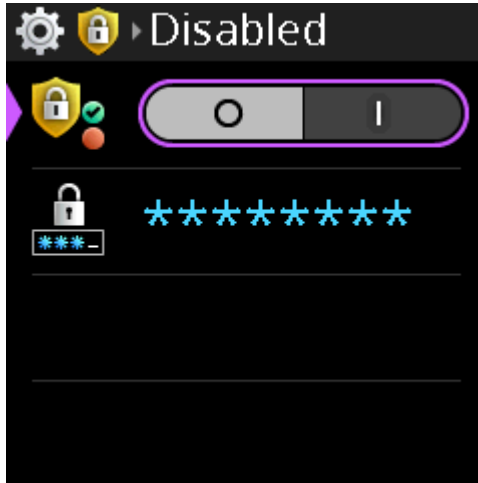

5. Rotate either **shaft encoder** to move the focus to Enabled.
6. Press the **SEL/MENU button** to confirm the change, or press the **CLR/BACK button** to abort changes.



Notice!

If a PIN already exists, you are able to enable or disable the PIN entry. However, after enabling the PIN entry when there is an existing PIN, when exiting the menu a prompt asks for the PIN before enabling authentication. This is to prevent accidental lockout.

9.5.2

Set PIN

Use the **Set PIN** menu item to set a security PIN code for the belt pack menu. The PIN is made up of a sequence of talk key button presses. When enabled, entry of this PIN is required to access the DBP menu structure.

PIN length can be 1 to 8 characters.

To **set the PIN**, do the following:

1. Navigate to the **Authentication menu item** (Setup | Authentication).
2. Press the **SEL/MENU button**.
3. Navigate to **Select PIN**.
4. Press the **SEL/MENU button**.
The field displays <Use A-D keys>.

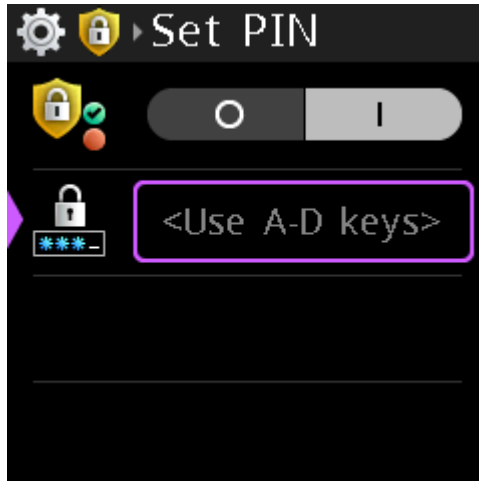

5. Press the **sequence for the PIN** to finish entering the PIN.
6. Press the **SEL/MENU button**.
7. Press the **CLR/BACK button to exit the screen**.
A Save? prompt appears on the screen.
8. Press the **SEL/MENU button** to confirm.
A confirm PIN window appears.
9. Enter the **newly created PIN**.
10. Press the **SEL/MENU button**.
The Confirm PIN window closes and the PIN is saved.



Notice!

If you leave this menu without enabling authentication or without changing the PIN, then you do not have to confirm the PIN.

9.6

Setup | Key Modes

Use the **Key Modes** menu item to configure the behavior of the DBP talk buttons.

Available options

Latching - Tap the talk key on, and then tap the talk key off. However, if you press and hold, the talk key turns on, but then turns off when you let the key go.

Momentary - The talk key is active as long as it is pressed.

Always on - The talk key is always on.

Always off - The talk key is always off.

To **configure the talk key modes**, do the following:

1. Navigate to the **Key Mode menu** (Setup | Key Modes).
2. Navigate to select the **talk key** to configure.
3. Press the **SEL/MENU button**.

The field becomes active.



4. Rotate either **shaft encoder** to scroll the available options.
5. Press the **SEL/MENU button** to confirm the change, or press the **CLR/BACK button** to abort changes.

9.7 Audio | Headset

Use the **Headset** menu item to configure sidetone and enable echo cancellation.



Notice!

Only insert or remove headsets from the DBP with the talk keys inactive. Insertion/removal of headsets on DBPs with active talk keys may produce brief amounts of noise on the network as contacts engage/disengage with the mating jacks while the DBP microphone is active.

9.7.1 Sidetone

Use the **Sidetone** menu item to configure the level, in dB, at which the user hears their own voice. Most people prefer some amount of sidetone to overcome the muffled sensation when talking, especially when wearing a dual-sided headset. There are three different sidetone values available for editing from this menu; XLR Sidetone, 3.5mm Sidetone, and Bluetooth Sidetone. Only one displays at a time, but the context changes depending upon the active mic selection.

The range for this field is Disabled, -30 dB to 0 dB

The default setting is -20 dB

To **set the sidetone**, do the following:

1. Navigate to the **Sidetone menu item** (Audio | Headset | Sidetone).
2. Press the **SEL/MENU button**.
The field becomes active.



3. Rotate either **shaft encoder** to adjust the level.
4. Press the **SEL/MENU button** to confirm the change, or press the **CLR/BACK button** to abort changes.

9.7.2

Echo Canceller

Use the **Echo Canceller** menu item to enable echo cancellation for the headset. Echo cancellation prevents feedback from occurring between the microphone and the speaker being used on the beltpack. If an echo is still present after being enabled, it is possible the echo is originating from another user on the network.

This feature is not available when the Bluetooth headset is selected as the active microphone.

To **enable Echo Cancellation**, do the following:

1. Navigate to the **Echo Canceller menu item** (Audio | Headset | Echo Canceller).
2. Press the **SEL/MENU button**.
The field becomes active.

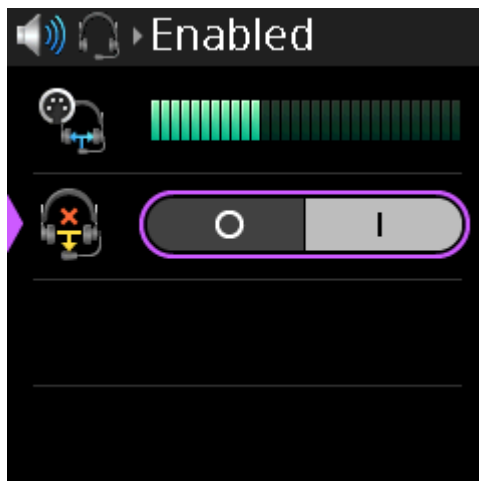

3. Rotate either **shaft encoder** to toggle between choices.
4. Press the **SEL/MENU button** to confirm the change, or press the **CLR/BACK button** to abort changes.

9.8 Audio | Microphone

Use the **Microphone** menu item to select the active mic, adjust mic gain for the active mic, enable the hot mic, set the noise gate for the active mic, select the XLR mic type, allow/disallow mic kill signals, and to send a mic kill signal.

9.8.1 Mic Select

Use the **Mic Select** menu item to select the active mic used with the belt pack. The selection made in this menu directly affects the menu item seen for mic gain in this menu, noise gating in this menu, whether the XLR Mic Type menu item is visible in this menu, and sidetone in the Headset menu. For example, if the mic type selected is XLR, the mic gain menu shows XLR gain. If the mic type selected is 3.5mm, the mic gain shows 3.5mm gain. The DBP has the ability to detect insertion and removal of headsets and automatically configure the active microphone setting based upon this.

- If there are no headsets installed in a DBP, the first headset inserted causes the Mic Select to automatically re-configure to the newly installed headset.
- If the headset associated with the active microphone is removed from the DBP, and if multiple headsets are installed, the Mic Select automatically switches to one of the remaining headsets as the active microphone.

To **select the active mic**, do the following:

1. Navigate to the **Mic Select menu item** (Audio | Microphone | Mic Select).
2. Press the **SEL/MENU button**.

The field becomes active.



3. Rotate either **shaft encoder** to scroll through the selections.
4. Press the **SEL/MENU button** to confirm the change, or press the **CLR/BACK button** to abort changes.

9.8.2 Mic Gain

Use the **Mic Gain** menu item to adjust the mic gain level, in dB, of the active mic. The range for this field is -10 dB to 10 dB. The default is 0 dB.



Notice!

Although the default Mic Gain is 0 dB for all mic selections, transmission levels of 3.5mm electret microphone vary significantly between different manufacturers and models. The adjustment range of ± 10 dB is provided to allow these 3.5mm microphones to be normalized to desired network levels.

To **adjust the mic gain**, do the following:

1. Navigate to the **Mic Gain menu item** (Audio | Microphones | Mic Gain).
2. Press the **SEL/MENU button**.

The field becomes active.



3. Rotate either **shaft encoder** to adjust the level.
4. Press the **SEL/MENU button** to confirm the change, or press the **CLR/BACK button** to abort changes.

9.8.3

Hot Mic

Use the **Hot Mic** menu item to enable or disable the hot mic feature. In the hot mic setting, audio from the mic goes out to the intercom without regard to the talk key state. When Hot Mic is not enabled, audio from the DBP is only sent to the intercom when a talk key is active.

By default, Hot Mic is disabled.

To **enable hot mic**, do the following:

1. Navigate to the **Hot Mic menu item** (Audio | Microphones | Hot Mic).
2. Press the **SEL/MENU button**.

The field becomes active.



3. Rotate either **shaft encoder** to toggle between choices.
4. Press the **SEL/MENU button** to confirm the change, or press the **CLR/BACK button** to abort changes.

9.8.4

Noise Gate

The **Noise Gate** menu item adjusts the noise gate for the active mic. The Mic Select menu item selects the active mic.

The noise gate defaults to a different value depending upon the microphone selected.

XLR = -72 dBu

3.5mm = -66 dBu

Bluetooth = -62 dBu

Available options: Disabled, -82 dBu to -42 dBu.

To **adjust noise gate level**, do the following:

1. Navigate to the **Noise Gate menu item** (Audio | Microphone | Noise Gate).
2. Press the **SEL/MENU button**.

The field becomes active.



NOTE: The blue arrows indicate the current noise level. You want to set the noise gate just above the current noise level.

1. Rotate either **shaft encoder** to adjust the level.
2. Press the **SEL/MENU button** to confirm the change, or press the **CLR/BACK button** to abort changes.

9.8.5

XLR Mic Type

Use the **XLR Mic Type** menu item to select the type of XLR mic.



Notice!

The XLR Mic Type menu item is only visible if the Mic Select is used to select the XLR mic.

The available options for this field are:

A = automatic detection of the XLR microphone type (either Electret or Dynamic)

E = Electret microphones

D = Dynamic microphones

Auto is the default setting.

To **select the XLR mic type**, do the following:

1. Navigate to the **XLR Mic Type menu item** (Audio | Microphone | XLR Mic Type).
2. Press the **SEL/MENU button**.

The field becomes active.



3. Rotate either **shaft encoder** to scroll through the selections.
4. Press the **SEL/MENU button** to confirm the change, or press the **CLR/BACK button** to abort changes.

9.8.6

Allow Mic Kill

Use the **Allow Mic Kill** menu item to allow an incoming mic kill signal to turn off the device's talk keys. Mic Kill is an inaudible signal sent by the belt pack that forces all devices on the line to stop talking.



Notice!

Incoming Mic Kill has no effect if Hot Mic is active or if any talk key mode is set to Always On.

The mic kill function does not work on Clear-Com analog belt packs.

By default, mic kill is allowed on the belt pack.

To **allow or not allow a mic kill signal**, do the following:

1. Navigate to the **Allow Mic Kill menu item** (Audio | Microphone | Allow Mic Kill).

- 2. Press the **SEL/MENU button**.
The field becomes active.

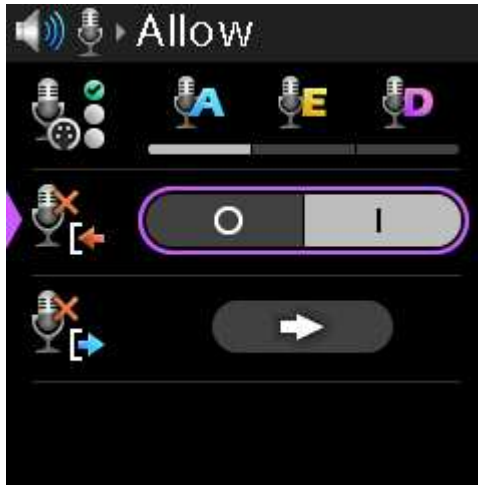

- 3. Rotate either **shaft encoder** to toggle the selections.
- 4. Press the **SEL/MENU button** to confirm the change, or press the **CLR/BACK button** to abort changes.

9.8.7

Send Mic Kill

Use the **Send Mic Kill** menu item to send an inaudible signal that forces all devices on the affected party lines with talk keys on to stop talking.

To **send a mic kill**, do the following:

- 1. Navigate to the **Send Mic Kill menu item** (Audio | Microphone | Send Mic Kill).



- 2. Press the **SEL/MENU button**.
A confirmation message appears.

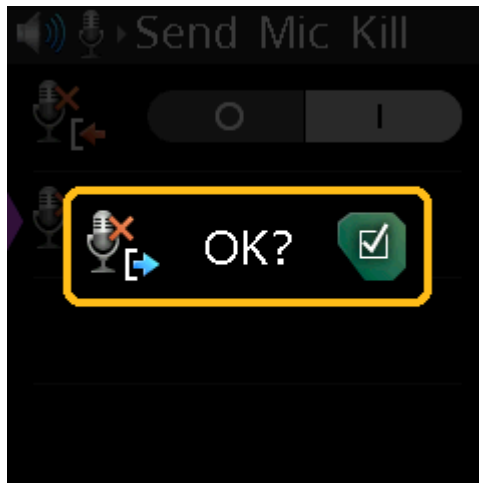

3. Press the **SEL/MENU button** to send the signal.
A Sent confirmation message appears.
OR
Press the **CLR/BACK button** to cancel the send.

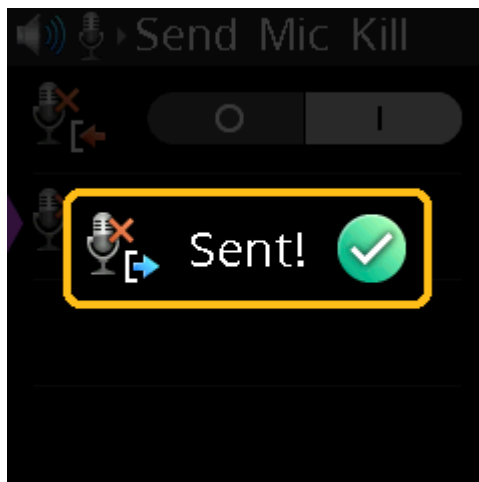

9.9 Audio | 3.5mm Aux

Use the **3.5mm Aux** menu items to select the Aux mode and adjust the Aux input and output gain levels.

If either Aux Input or Aux Output is enabled, and if the 3.5mm microphone had been configured as active, this forces the Mic Select setting to XLR. The AUX functions and 3.5mm headset microphone cannot be simultaneously active.

9.9.1 Aux Mode

Use the **Aux Mode** menu item to disable Aux, enable Aux Input, or enable Aux Output.

To **set the aux mode**, do the following:

1. Navigate to the **Aux Mode menu item** (Audio | 3.5mm Aux | Aux Mode).
2. Press the **SEL/MENU button**.
The field becomes active.

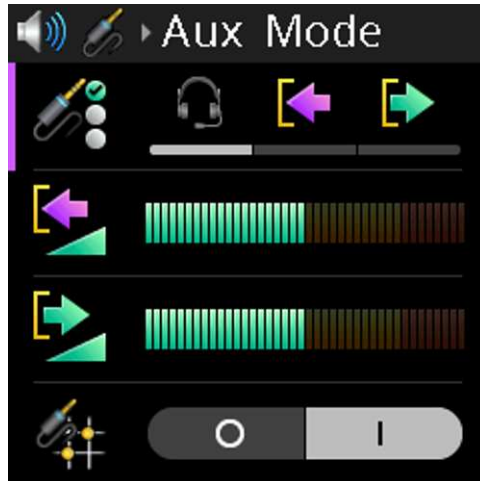

3. Rotate either **shaft encoder** to scroll through the selections.
4. Press the **SEL/MENU button** to confirm the change, or press the **CLR/BACK button** to abort changes.

9.9.2

Input Gain

Use the **Input Gain** menu item to adjust the volume of the Aux Input.

To **adjust the input gain**, do the following:

1. Navigate to the **Input Gain menu item** (Audio | Aux Levels | Input Gain).
2. Press the **SEL/MENU button**.
The field becomes active.



3. Rotate either **shaft encoder** to adjust the level.
4. Press the **SEL/MENU button** to confirm the change, or press the **CLR/BACK button** to abort changes.

9.9.3

Output Gain

Use the **Output Gain** menu item to adjust the Aux output volume.

To **adjust the output gain**, do the following:

1. Navigate to the **Output Gain menu item** (Audio | Aux Levels | Output Gain).
2. Press the **SEL/MENU button**.
The field becomes active.



3. Rotate either **shaft encoder** to adjust the level.
4. Press the **SEL/MENU button** to confirm the change, or press the **CLR/BACK button** to abort changes.

9.9.4

Aux Stereo Mix



Notice!

Before you enable Aux Stereo Mix, you must first set Aux Mode to Input. For more information, see *Aux Mode*, page 74.

Use the Aux 3.5mm menu option **Aux Stereo Mix** option to enable the Aux Stereo Mix feature.

The Aux Stereo Mix feature allows you to mix Aux Input, From Intercom, or OMNEO Ch 2 audio to the left, right or both headphones on a 5-pin XLR headset.

Available options are Disabled, Enabled, and L/R Swap

For more information on mixing, see *Audio | Mixer*, page 80.



To **enable Aux Stereo Mix**, do the following:

1. Navigate to the **Aux Stereo Mix** option (Audio | Aux Levels | Aux Stereo Mix).



2. Press the **SEL/MENU** button.
The field becomes active.
3. Rotate either **shaft encoder** to toggle between choices.



4. Press the **SEL/MENU** button to confirm the change, or press the **CLR/BACK** button to abort changes.

To **enable Aux Stereo Mix in AZedit**, do the following:

1. Enter the **Port/Alpha** for the device in the Port/Alpha field.
2. Click the **Keypanel Configuration** button.

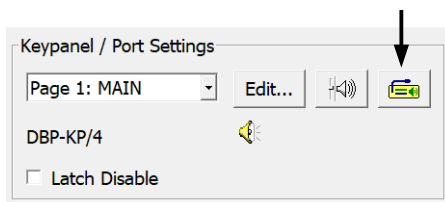

3. Select the **Stereo Mix to XLR Headset** check box.

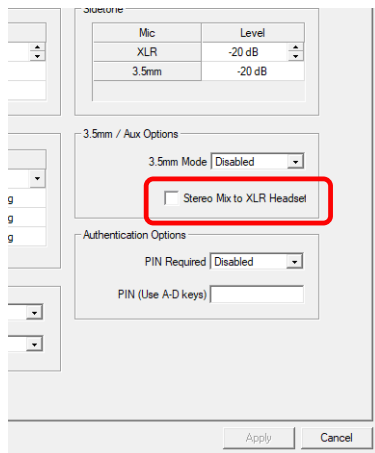

4. Click **Apply**.
5. Send **changes** to the intercom.

9.10 Audio | BT Aux Levels

9.10.1 Input Gain

Use the **Input Gain** menu item to adjust the Bluetooth Aux input gain level.

To **adjust the input gain**, do the following:

1. Navigate to the **Input Gain menu item** (Audio | BT Aux Levels | Input Gain).
2. Press the **SEL/MENU button**.

The field becomes active.

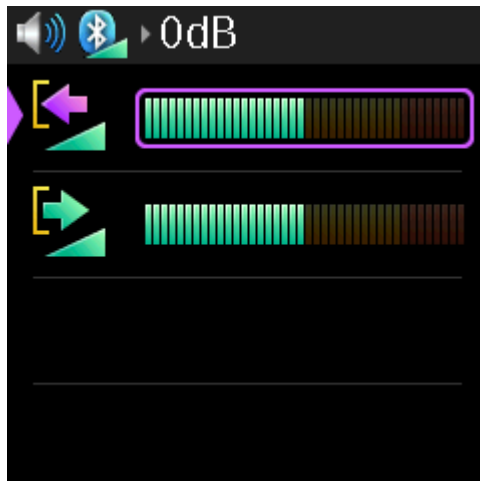

3. Rotate either **shaft encoder** to adjust the level.
4. Press the **SEL/MENU button** to confirm the change, or press the **CLR/BACK button** to abort changes.

9.10.2 Output Gain

Use the **Output Gain** menu item to adjust the Bluetooth Aux output gain levels.

To **adjust the output gain**, do the following:

1. Navigate to the **Output Gain menu item** (Audio | BT Aux Levels | Output Gain).
2. Press the **SEL/MENU button**.

The field becomes active.

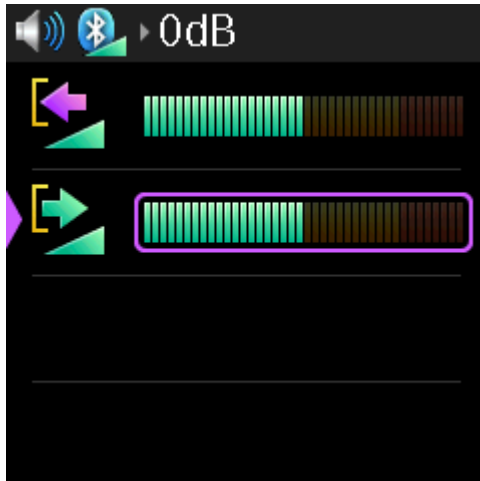

3. Rotate either **shaft encoder** to adjust the level.
4. Press the **SEL/MENU button** to confirm the change, or press the **CLR/BACK button** to abort changes.

9.11 Audio | OMNEO CH 2 Levels

Use the **OMNEO CH 2 Levels** menu item to configure OMNEO Aux input and output gain levels for OMNEO channel 2. OMNEO Aux input and output can be mixed to a headset or to the intercom.

9.11.1 Input Gain

Use the **Input Gain** menu item to adjust the level of input audio gain on OMNEO channel 2. The range for this field is -10 dB to 10 dB. The default is 0 dB.

To **adjust input gain**, do the following:

1. Navigate to the **Input Gain menu item** (Audio | OMNEO CH2 Levels | Input Gain).
2. Press the **SEL/MENU button**.
The field becomes active.

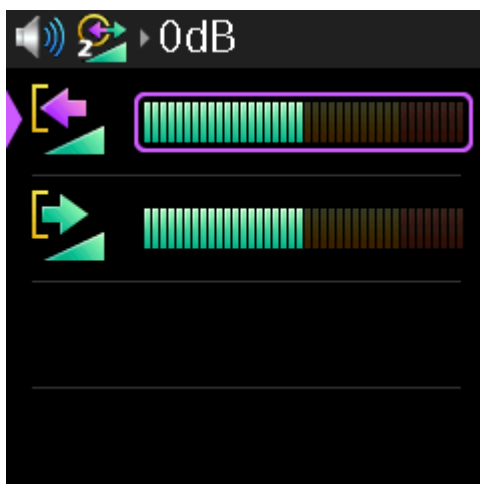

3. Rotate either **shaft encoder** to adjust the level.
4. Press the **SEL/MENU button** to confirm the change, or press the **CLR/BACK button** to abort changes.

9.11.2

Output Gain

Use the **Output Gain** menu item to adjust the level of output audio gain on OMNEO channel 2.

The range for this field is -10 dB to 10 dB

The default is 0 dB.

To **adjust output gain**, do the following:

1. Navigate to the **Output Gain menu item** (Audio | OMNEO CH2 Levels | Output Gain).
2. Press the **SEL/MENU button**.

The field becomes active.

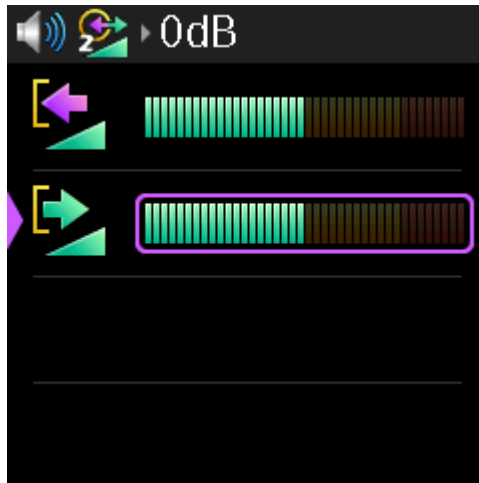

Figure 9.3:

3. Rotate either **shaft encoder** to adjust the level.
4. Press the **SEL/MENU button** to confirm the change, or press the **CLR/BACK button** to abort changes.

9.12

Audio | Mixer

Use the **Mixer** menu item to route select input audio signals to different destinations. The following destinations are available:

- Headset L+R
- Headset Left
- Headset Right
- To Intercom
- 3.5 mm Aux Out
- OMNEO Ch2 Out
- Bluetooth Out

9.12.1

Headset L+R

Use the **Headset L+R** menu item to select input sources routed to both the left and right channels of the headset at the same time.

By default, From Intercom is selected. If Bluetooth is installed, then From Intercom and BT are selected.

Available options for this field are From Intercom, 3.5mm Aux In, OMNEO Ch2 In, and Bluetooth In (if installed).

To **select the input source for the headset L+R**, do the following:

1. Navigate to the **Headset L+R menu item** (Audio | Mixer | Headset L+R).

2. Press the **SEL/MENU button**.

The field becomes active.



3. Rotate the **A/C shaft encoder** to scroll through the selections.
4. Rotate the **B/D shaft encoder** to select or deselect the item.
5. Press the **SEL/MENU button** to confirm the change, or press the **CLR/BACK button** to abort changes.

9.12.2

Headset Left

Use the **Headset Left** menu item to select which input sources are routed to the left channel of the headset independently to those routed to the right channel.

By default, From Intercom is selected. If Bluetooth is installed, then From Intercom and BT are selected.

Available options for this field are From Intercom, 3.5mm Aux In, OMNEO Ch2 In, and Bluetooth In (if installed).

To **select which input sources are routed to the left channel of the headset**, do the following:

1. Navigate to the **Headset Left menu item** (Audio | Mixers | Headset Left).
2. Press the **SEL/MENU button**.

The field becomes active.



3. Rotate the **A/C shaft encoder** to scroll through the selections.
4. Rotate the **B/D shaft encoder** to select or deselect the item.

5. Press the **SEL/MENU button** to confirm the change, or press the **CLR/BACK button** to abort changes.

9.12.3

Headset Right

Use the **Headset Right** menu item to select which input sources are routed to the right channel of the headset independently to those routed to the left channel.

By default, From Intercom is selected. If Bluetooth is installed, then From Intercom and BT are selected.

Available options for this field are From Intercom, 3.5mm Aux In, OMNEO Ch2 In, and Bluetooth In (if installed).

To **select which input sources are routed to the right channel of the headset**, do the following:

1. Navigate to the Headset Right menu item (Audio | Mixers | Headset Right).
2. Press the **SEL/MENU button**.
The field becomes active.



3. Rotate the **A/C shaft encoder** to scroll through the selections.
4. Rotate the **B/D shaft encoder** to select or deselect the item.
5. Press the **SEL/MENU button** to confirm the change, or press the **CLR/BACK button** to abort changes.

9.12.4

To Intercom

Use the **To Intercom** menu item to select the input sources routed to the intercom.

By default, the Active Mic resource is selected.

Available options for this field are Active Mic, 3.5mm Aux In, OMNEO Ch2 In, and Bluetooth In (if available).

To **select the input sources routed To Intercom**, do the following:

1. Navigate to the **To Intercom menu item** (Audio | Mixers | To Intercom).
2. Press the **SEL/MENU button**.
The field becomes active.



3. Rotate the **A/C shaft encoder** to scroll through the selections.
4. Rotate the **B/D shaft encoder** to select or deselect the item.
5. Press the **SEL/MENU button** to confirm the change, or press the **CLR/BACK button** to abort changes.

9.12.5

3.5mm Aux Out

Use the **3.5mm Aux Out** menu item to select input sources routed to 3.5mm Aux Out.

Available options for this field are From Intercom, Active Mic, OMNEO Ch2 In, and Bluetooth In (if available).

To **select input sources routed to the 3.5mm Aux Out**, do the following:

1. Navigate to the **3.5mm Aux Out menu item** (Audio | Mixer | 3.5mm Aux Out).
2. Press the **SEL/MENU button**.
The field becomes active.



3. Rotate the **A/C shaft encoder** to scroll through the selections.
4. Rotate the **B/D shaft encoder** to select or deselect the item.
5. Press the **SEL/MENU button** to confirm the change, or press the **CLR/BACK button** to abort changes.

9.12.6

OMNEO Ch2 Out

Use the **OMNEO Ch2 Out** menu item to select input resources routed to OMNEO Ch2 Out.

Available options for this field are From Intercom, 3.5mm Aux In, Active Mic, and Bluetooth In (if installed).

To **select the input sources routed to OMNEO Ch2 Out**, do the following:

1. Navigate to the **OMNEO Ch2 Out menu item** (Audio | Mixers | OMNEO Ch2 Out).
2. Press the **SEL/MENU button**.

The field becomes active.



3. Rotate the **A/C shaft encoder** to scroll through the selections.
4. Rotate the **B/D shaft encoder** to select or deselect the item.
5. Press the **SEL/MENU button** to confirm the change, or press the **CLR/BACK button** to abort changes.

9.12.7

Bluetooth Out

Use the **Bluetooth Out** menu item to select the input source routed to the Bluetooth device.



Notice!

This menu item does not appear if a Bluetooth dongle is not detected on the USB port.

By default, Active Mic is selected.

Available options for this field are From Intercom, 3.5mm Aux In, OMNEO Ch2 In, and Active Mic.

To **select the input source to route to Bluetooth Out**, do the following:

1. Navigate to the **Bluetooth Out menu item** (Audio | Mixers | Bluetooth Out).
2. Press the **SEL/MENU button**.

The field becomes active.



3. Rotate the **A/C shaft encoder** to scroll through the selections.
4. Rotate the **B/D shaft encoder** to select or deselect the item.
5. Press the **SEL/MENU button** to confirm the change, or press the **CLR/BACK button** to abort changes.

9.13 Call Alerts

Use the **Call Alerts** menu to configure how the belt pack notifies the user of an incoming call signal.

9.13.1 Call Beep

Use the **Call Beep** menu item to enable an audible alert to play when receiving a call signal. The default setting is call beep enabled.

To **enable call beep**, do the following:

1. Navigate to the **Call Beep menu item** (Call Alerts | Call Beep).
2. Press the **SEL/MENU button**.

The field becomes active.

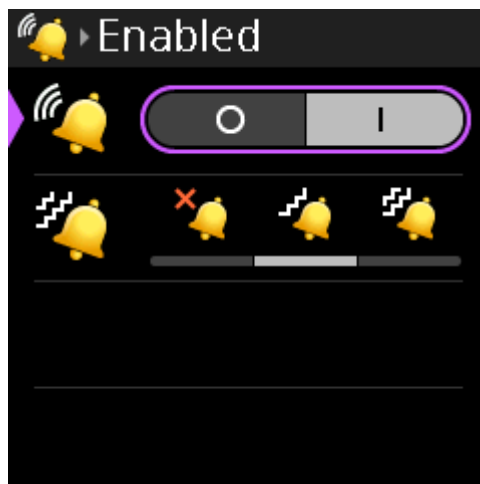

3. Rotate either **shaft encoder** to toggle the selections.
4. Press the **SEL/MENU button** to confirm the change, or press the **CLR/BACK button** to abort changes.

9.13.2 Call Vibration

Use the **Call Vibration** menu item to set the vibration intensity when receiving a call signal.

**Notice!**

You can use call beep and call vibration at the same time, if desired.

There are three settings Off, Low, and High.

The default setting is low vibration.

To **set the vibration intensity**, do the following:

1. Navigate to the **Call Vibration menu item** (Call Alerts | Call Vibration).
2. Press the **SEL/MENU button**.
The field becomes active.

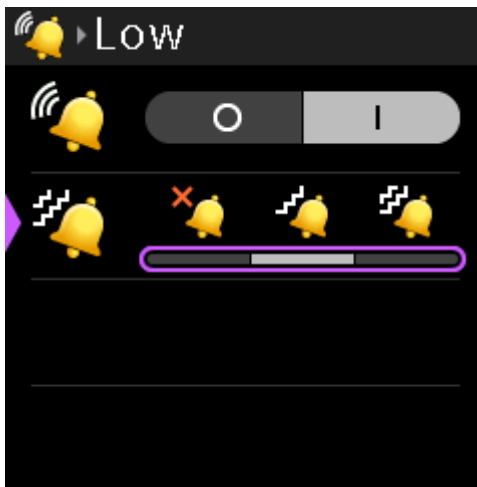

3. Rotate either **shaft encoder** to scroll through the selections.
Cycling through the haptic settings for low and high, the DBP vibrates to give an indication of the vibration strength and frequency.
4. Press the **SEL/MENU button** to confirm the change, or press the **CLR/BACK button** to abort changes.

9.14**Information**

Use the **Information** menu item to display the firmware versions of the various components of the DBP as well as the serial number and the main board ID.

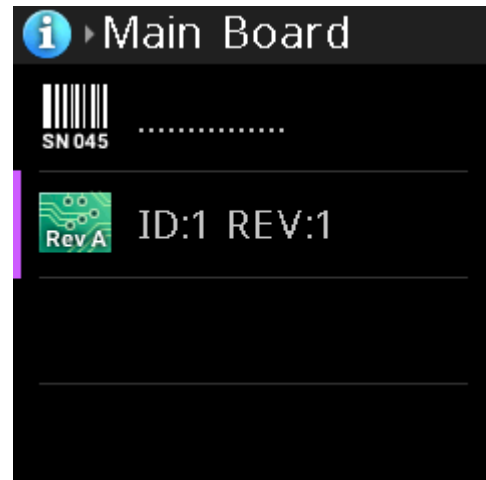

To **display this information**, do the following:

1. Navigate to the **Information menu item**.
2. Press the **SEL/MENU button**.
The menu opens.
3. Rotate either **shaft encoder** to scroll through the selections.
Cycling through the haptic settings for low and high, the DBP vibrates to give an indication of the vibration strength and frequency.
4. Press the **CLR/BACK button** to exit the menu.

9.15 Bluetooth



Notice!

This menu item cannot be accessed (and is disabled at the top-level menu) if a Bluetooth dongle is not detected.

Entering the Bluetooth menu enables discoverability on the DBP. This means that other Bluetooth devices, such as cell phones, may see the DBP.

While in this menu, it is possible for a cell phone to initiate a pairing request to the DBP. A popup prompt appears asking you to allow pairing.

9.15.1 Ready to Pair

The **Ready to Pair** menu item shows nearby discovered Bluetooth devices that are available for pairing to the DBP.

To **select and pair a device to the belt pack**, do the following:

1. Navigate to **the Ready to Pair menu item** (Bluetooth | Ready to Pair).
2. Press the **SEL/MENU button**.
The field becomes active.



3. Rotate either **shaft encoder** to scroll available devices.
4. Press the **SEL/MENU button** to select a device for pairing.
A Pair... prompt appears.



5. Press the **SEL/MENU button** to start pairing.
A progress bar appears on the screen. A message appears on the screen when pairing is complete.

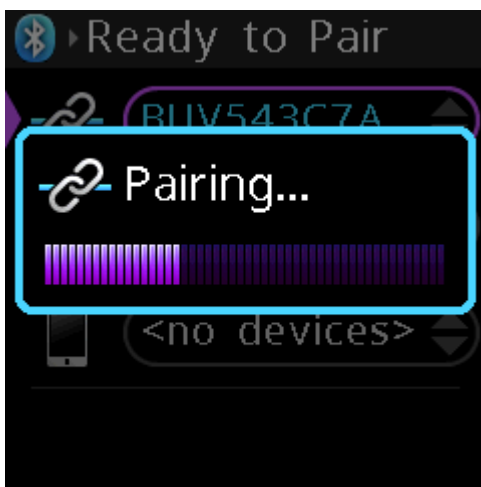

Notice!

You may need to allow pairing to proceed on the device to which the belt pack is connecting.

9.15.2

Paired Headsets

The Paired Headsets menu item contains a list of headsets previously paired to the DBP. Use this menu item to connect, disconnect, or unpair Bluetooth enabled headsets for use with the belt pack.



Notice!

If the headset and belt pack are paired, and either one of them is turned off or moved out of range from each other, the headset attempts to connect when both devices are in range of each other. In which case, a popup connection request appears.

To **connect, disconnect, or unpair a Bluetooth headset**, do the following:

1. Navigate to the **Paired Headsets menu item** (Bluetooth | Paired Headsets).

2. Press the **SEL/MENU button**.
The field is active if there are headsets previously paired with the DBP; otherwise, the menu item does not activate.
3. Rotate either **shaft encoder** to scroll through available devices.
4. Press the **SEL/MENU button** to confirm to select a headset to work with.
A popup window appears with Connect and Unpair buttons. If you are already connected, the options are Disconnect and Unpair.

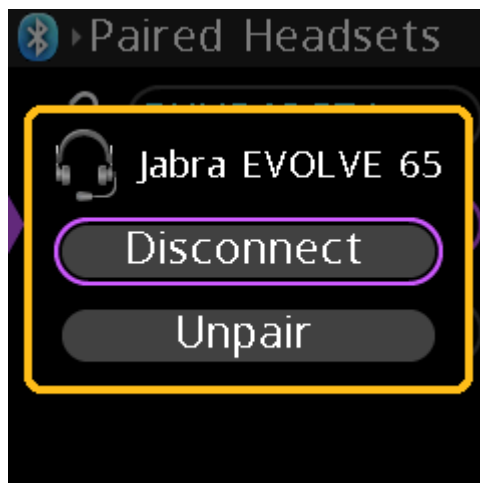
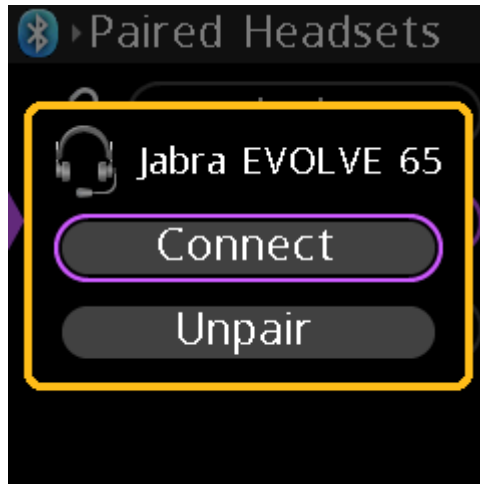

5. Rotate either **shaft encoder** to select Connect or Disconnect.
6. Press the **SEL/MENU button** to initiate the action.
A Connecting progress bar appears on the screen. When it finishes the connection, a Completed message appears on the screen. The connection attempt can also fail sometimes and shows a red failed message. If this occurs, attempt the connection again.
If disconnecting, a popup window appears with a Disconnected message.

To **unpair a Bluetooth headset**, do the following:

1. Navigate to the **Paired Headsets menu item** (Bluetooth | Paired Headsets).
2. Press the **SEL/MENU button**.
The field is active if Bluetooth devices are available, otherwise the menu item does not activate.
3. Rotate either **shaft encoder** to scroll through available devices.

4. Press the **SEL/MENU button** to confirm.
A popup window appears.
5. Rotate either **shaft encoder** to select Unpair.
6. Press the **SEL/MENU button** to confirm the unpairing.
A popup window appears with an Unpaired message.

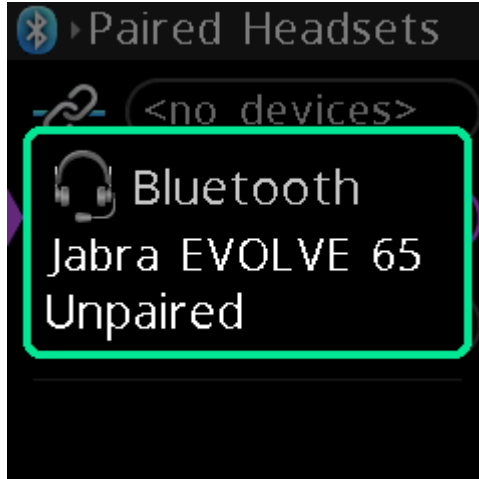

9.15.3

Paired Aux Devs

The **Paired Aux Devs** menu item contains a list of phone or other aux devices previously paired to the DBP. Use this menu item to connect, disconnect, and unpair Bluetooth enabled devices for use with the belt pack.

To **connect, disconnect, or unpair a Bluetooth device**, do the following:

1. Navigate to the **Paired Aux Devs menu item** (Bluetooth | Paired Aux Devs).
2. Press the **SEL/MENU button**.
The field is active if Bluetooth devices are available, otherwise the menu item does not activate.
3. Rotate either **shaft encoder** to scroll through available devices.
4. Press the **SEL/MENU button** to select the device.
A popup window appears with Connect and Unpair or Disconnect and Pair buttons.



5. Rotate either **shaft encoder** to select Connect, Unpair, Disconnect or Pair.
6. Press the **SEL/MENU button** to initiate a connection.
A progress bar appears on the screen. When it finishes the connection, a status message appears on the screen.

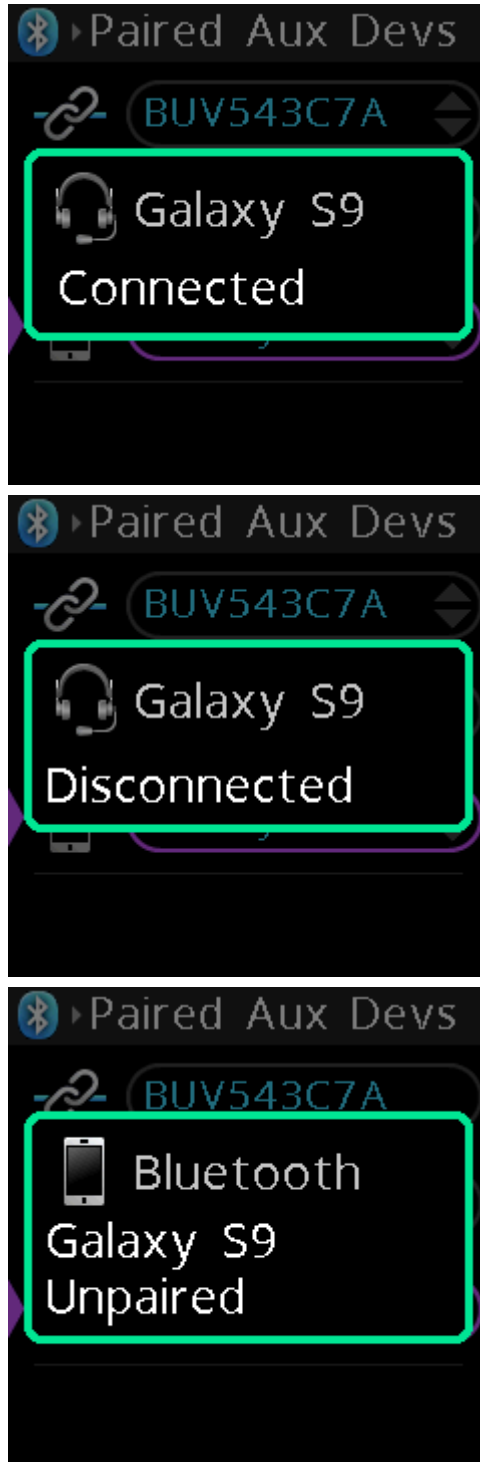

9.16 Display

Use the **Display** menu to configure display mode, brightness, screen saver timeout, and the orientation of the screen.

9.16.1 Display Mode

Use the **Display Mode** menu item to select a predefined display brightness. There are three modes from which to choose.

The default brightness settings for each mode are:

Normal	76% brightness
Dim	26% brightness
Dark	0% brightness

Modifications to these defaults are done in the Brightness menu.

To **set the display mode**, do the following

1. Navigate to the **Display Mode menu item** (Display | Display Mode).
2. Press the **SEL/MENU button**.
The field becomes active.



3. Rotate either **shaft encoder** to scroll the available options.



Notice!

As you switch between the different modes, the Brightness bar graph changes to show the brightness level for that mode. You can edit the brightness of the mode by selecting the mode and then modifying the brightness of the selected mode in the Brightness menu item.

4. Press the **SEL/MENU button** to confirm the change, or press the **CLR/BACK button** to abort changes.

9.16.2

Brightness

Use the **Brightness** menu item to adjust the brightness for the currently selected display mode. Adjustments to the brightness appear in increments of two, from 0% to 100%.

To **set the brightness**, do the following:

1. Navigate to the **Brightness menu item** (Display | Brightness).
2. Press the **SEL/MENU button**.
The field becomes active.



3. Rotate either **shaft encoder** to increase or decrease the display brightness.
4. Press the **SEL/MENU button** to confirm the change, or press the **CLR/BACK button** to abort changes.

9.16.3

Screen Saver

Use the **Screen Saver** menu item to configure the amount of time before the screen saver activates. You can download your own screen saver image via AZedit. The minimum image size is 16x16 pixels; the maximum size cannot exceed 120x120 pixels. For more information on downloading an image, see *Download screen saver images or splash screen images, page 46*.

The DBP contains a default screen saver of the RTS logo.

Available options: *Disabled, 5 Minutes, 10 Minutes, 20 Minutes, 30 Minutes, 1 Hour, 2 Hours, 4 Hours, 6 Hours, 8 Hours, 10 Hours, and 12 Hours*.

To **configure the screen saver**, do the following:

1. Navigate to the **Screen Saver menu item** (Display | Screen Saver).
2. Press the **SEL/MENU button**.

The field becomes active.



3. Rotate either **shaft encoder** to scroll through the options.
4. Press the **SEL/MENU button** to confirm the change, or press the **CLR/BACK button** to abort changes.

9.16.4

Screen Flip

Use the **Screen Flip** menu item to set the orientation of the display screen.



Notice!

The correspondence of the navigation buttons and shaft encoders remain unchanged after the initiation of a screen flip. In addition, key assignments remain associated with the original A, B, C, and D keys, independent of screen orientation.

To **use screen flip**, do the following:

1. Navigate to the **Screen Flip menu item** (Display | Screen Flip).
2. Press the **SEL/MENU button**.
The field becomes active.



3. Rotate either **shaft encoder** to enable screen flip.
The screen display flips.

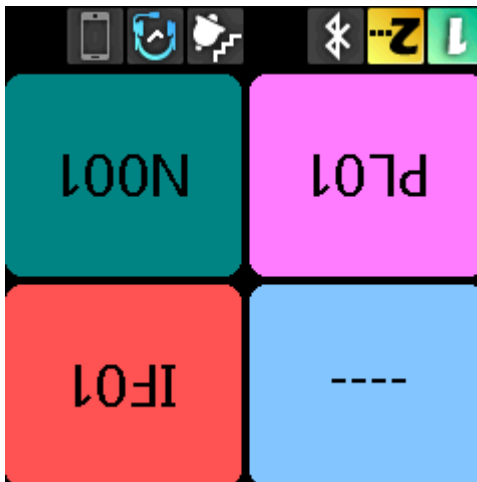







4. Press the **SEL/MENU button** to confirm the change, or press the **CLR/BACK button** to abort changes.

10

Icons

The Digital Belt Pack has a graphical icon menu system to navigate easily to menu items.

		Setup Menu	Enter the Setup menu
		Network Menu	Enter the Network menu
		Device Name	Configure the Device Name
		DHCP	Enable/Disable DHCP
		IP Address	Configure the IP Address
		Netmask	Configure the Netmask
		Gateway	Configure the Gateway Address
		DNS Server	Configure the DNS Server
		Domain	Configure the Domain
		MAC Address	Display the MAC address
		Offers	Enter the Offers menu
		DBP Offers	Select a DBP Offer
		Aux Offers	Select an Aux Offer
		Key Assignments	Enter Key Assignment Mode
		Service	Enter the Service menu
		Tone	Enable/Disable the Tone Generator
		Test Mode	Enter Test Mode
		User Reset	Perform a User Reset
		Factory Reset	Perform a Factory Reset
		Authentication	Enter the Authentication menu
		Require PIN	Configure PIN requirement
		Set PIN	Set the PIN
		Key Modes	Enter the Key Modes menu
		Key A	Select the key mode for Key A
		Key B	Select the key mode for Key B
		Key C	Select the key mode for Key C
		Key D	Select the key mode for Key D
		Audio	Enter the Audio menu

		Headset	Enter the Headset menu
		Sidetone	Adjust the Sidetone. The type of sidetone adjustment (XLR, Bluetooth, or 3.5mm) is dependent upon the active mic selection made in the Mic Select menu
		Echo Canceller	Enable/Disable the Echo Canceller
		Microphone	Enter the Microphone menu
		Mic Select	Select the Active Mic
		Mic Gain	Adjust Mic Gain The type of mic gain adjustment (XLR, Bluetooth, or 3.5mm) is dependent upon the active mic selection made in the Mic Select menu
		Hot Mic	Enable or Disable Hot Mic
	  	Noise Gate	Adjust the Noise Gate level The type of noise gate adjustment (XLR, Bluetooth, or 3.5mm) is dependent upon the active mic selection made in the Mic Select menu.
		XLR Mic Type	Select the XLR Mic Type
		Allow Mic Kill	Enable or Disable Mic Kill
		Send Mic Kill	Send Mic Kill Signal
		3.5mm Aux	Enter the 3.5mm Aux Menu
		Aux Mode	Configure the Aux Mode
		Input Gain	Adjust Aux Input Gain
		Output Gain	Adjust Aux Output Gain
		Aux Stereo Mix	Enable or disable Aux Stereo Mix
		BT Aux Levels	Enter BT Aux Levels menu
		Input Gain	Adjust Bluetooth Input Gain
		Output Gain	Adjust Bluetooth Output Gain
		OMNEO Ch2 Levels	Enter OMNEO Ch2 Levels menu
		Input Gain	Adjust OMNEO Ch 2 Input Gain
		Output Gain	Adjust OMNEO Ch 2 Output Gain
		Mixer	Enter the Mixer menu
		Headset L+R	Configure the mixes to Headset Left and Right

























	Headset Left	Configure the mixes to Headset Left only
	Headset Right	Configure the mixes to Headset Right only
	To Intercom	Configure the mixes to To Intercom
	3.5mm Aux Out	Configure the mixes to 3.5mm Aux Out
	OMNEO Ch2 Out	Configure the mixes to OMNEO Ch2 Out
	Bluetooth Out	Configure the mixes to Bluetooth Out
	Call Alerts	Enter the Call Alerts menu
	Call Beep	Enable/Disable Call Beep
	Call Vibration	Select Call Vibration intensity
	Info	Enter the Information menu
	DBP Version	Display the DBP version
	Bootcode Version	Display the Bootcode version
	DSP Version	Display the DSP version
	OMNEO Version	Display the OMNEO version
	Serial Number	Display the Serial Number
	Hardware Revision	Display the Hardware Revision
	Bluetooth	Enter the Bluetooth menu
	Ready to Pair	Pair available devices
	Paired Headsets	Connect, Disconnect, or Unpair Bluetooth headsets
	Paired Aux Devices	Connect, Disconnect, or Unpair Bluetooth devices
	Display	Enter the Display menu
	Display Mode	Configure the Display Mode
	Brightness	Adjust the Display Brightness
	Screen Saver	Configure the Screen Saver
	Screen Flip	Configure the Screen Orientation

Table 10.3: Digital Belt Pack Icon Table

















11 Technical data

Power Supply	
DC PoE:	802.3af / 802.3at
Maximum Power Consumption:	4.0 W (PoE DC Input)
Environmental	
Operating Temperature:	-4° F to 113° F (-20° C to 45° C) 5% to 90% relative humidity
Storage Temperature:	-4° F to 158° F (-20° C to 70° C) 15% to 90% relative humidity
Dimensions	
	5.51 in. (140 mm) L x 3.94 in. (100 mm) W x 2.64 in. (67 mm) D
Weight	
DBP:	0.75 lbs. (340 g)
Microphone Pre Amplifier	
XLR Input	
Electret Mic Input:	-42.5 dBu Nominal
Dynamic Mic Input:	-50 dBu Nominal
Frequency Response (LEC Disabled):	120 Hz to 20 kHz
Frequency Response (LEC Enabled)	120 Hz to 7.4 kHz
3.5 mm Input	
Electret Mic Input:	-42.5 dBu Nominal
Frequency Response (LEC Disabled):	120 Hz to 20 kHz
Frequency Response (LEC Enabled)	120 Hz to 7.4 kHz
Bluetooth Input	
Frequency Response (LEC Disabled)	70 Hz to 3.4 kHz
Headphone Amplifier	
XLR Headphone Response (150 Ohm load):	30 Hz to 3.4 kHz
3.5mm Headphone Response (32 Ohm load)	50 Hz to 19 kHz
Bluetooth Headphone Response	30 Hz to 3.4 kHz
Aux In	
Nominal Input	-4.3 dBu
Frequency Response (600 Ohm load)	50 Hz to 20 kHz
Aux Out	
Nominal Output	2.2 dBu

Frequency Response (600 Ohm load)	25 Hz to 20 kHz
OMNEO Ports (PoE In and PoE Out)	
Maximum Capacity:	2 Full-duplex ports
Copper Connector Type:	RJ-45
Format:	IEEE 802.3 compliant
Copper Ethernet Speed:	100/1000 Mbps
Bluetooth	
Bluetooth Version:	4.0
Supported dongles:	IO Gear GBU522 LM Technologies LM506
Range:	15 ft. (5 m)
Audio Codec:	SBC
TFT Display	
Active Area:	27.72 mm (wide) x 27.72 mm (high)
Dot Resolution:	240 x 240 pixels
Color Resolution:	16-bit (64 K) RGB color
View Angle:	80° (typical, all directions)
Protective Lens:	Anti-glare / Anti-reflective
Approvals:	
	CE compliant
	UL certified
	IP-53 rated (ingress protection)

Connector pin-outs

PoE Connector

Pins at switch	T568A color	T568B color	10/100 mode B, DC on spares		10/100 mode A, mixed DC & data		1000 (1gigabit) mode B, DC & bi-data		1000 (1 giagbit) mode A, DC & bi-data	
Pin 1	 White/green stripe	 White/green stripe	RX +		RX +	DC +	TxRx A +		TxRx A +	DC +
Pin 2	 Green solid	 Orange solid	RX -		RX -	DC +	TxRx A -		TxRx A -	DC +
Pin 2	 White/orange stripe	 White/green stripe	TX +		TX +	DC -	TxRx B +		TxRx B +	DC -
Pin 3	 Blue solid	 Blue solid		DC +	Unused		TxRx C +	DC +	TxRx C +	
Pin 4	 White/blue stripe	 White/blue stripe		DC +	Unused		TxRx C -	DC +	TxRx C -	
Pin 5	 Orange solid	 Green solid	TX -		TX -	DC -	TxRx B -		TxRx B -	DC -
Pin 6	 White/brown stripe	 White/brown stripe		DC -	Unused		TxRx D +	DC -	TxRx D +	
Pin 7	 Brown color	 Brown color		DC -	Unused		TxRx D -	DC -	TxRx D -	

Headset Connector

	5-Pin Dynamic	5-Pin Electret	4-Pin Dynamic	4-Pin Electret
Pin 1	Mic -	Ground	Mic -	Ground
Pin 2	Mic +	Mic	Mic +	Mic
Pin 3	Speaker -	Speaker -	Speaker -	Speaker -
Pin 4	Left Speaker +	Left Speaker +	Speaker +	Speaker +
Pin 5	Right Speaker +	Right Speaker +	N/A	N/A

Aux /3.5mm Connector

	Headset Mode	Aux Input	Aux Output
Tip	Left Speaker	Left Input	Left Output
Ring 1	Right Speaker	Right Input	Right Output
Ring 2	Ground		
Sleeve	Mic	Ground	Ground

USB Connector

Pin	Data
Pin 1	+5V
Pin 2	Data -
Pin 3	Data +
Pin 4	Ground

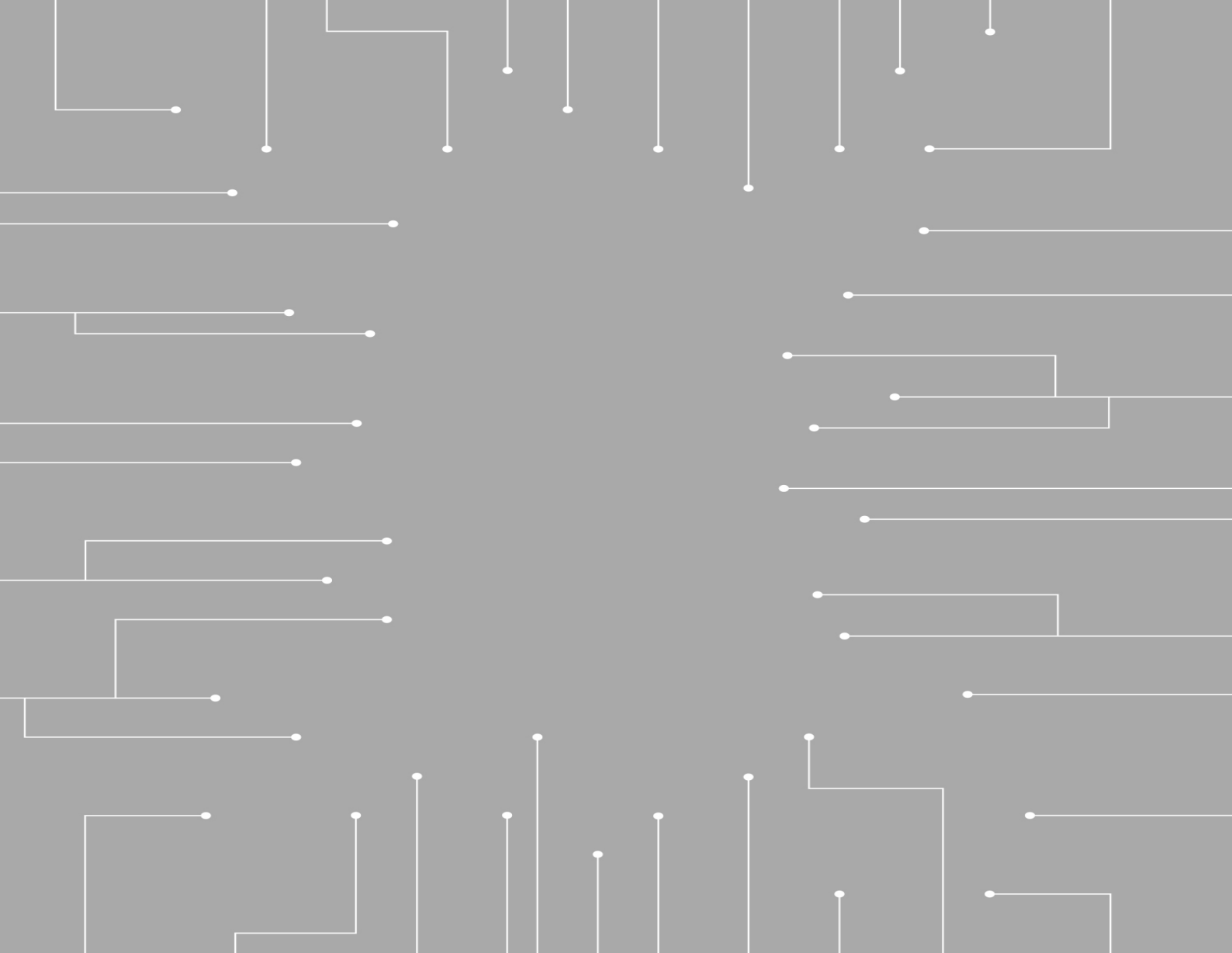

Bosch Security Systems, LLC

130 Perinton Parkway
Fairport, NY 14450
USA

www.rtsintercoms.com

© Bosch Security Systems, LLC, 2024

EU importer:

Bosch Sicherheitssysteme GmbH

Robert-Bosch-Platz 1
70839 Gerlingen
Germany

© Bosch Sicherheitssysteme GmbH, 2024